

# SUPER MINDS

Workbook 6

Herbert Puchta

Günter Gerngross

Peter Lewis-Jones



Herbert Puchta

Günter Gerngross

Peter Lewis-Jones

# SUPER Minds

**Workbook 6**



این مجموعه با لوگوی مرجع زبان ایرانیان  
به صورت نشر برخط و حامل به ثبت رسیده است.  
کپی برداری از آن خلاف قانون، شرع و اخلاق است و شامل پیگرد خواهد شد.



# Contents

●	Back to school	4
1	The treasure	10
2	Future transport	22
3	Ancient Egypt	34
4	Olympic sports	46
5	In London	58
6	Crazy inventions	70
7	This is Houston	82
8	A cold place	94
9	The Jurassic Age	106
●	My portfolio writing practice	118
●	Irregular verbs	127



# Back to school

## 1 Match the two halves of the words.

- |              |   |                                     |       |
|--------------|---|-------------------------------------|-------|
| 1 tennis     | a | <input type="checkbox"/>            | rack  |
| 2 basketball | b | <input type="checkbox"/>            | pitch |
| 3 school     | c | <input checked="" type="checkbox"/> | court |
| 4 running    | d | <input type="checkbox"/>            | bin   |
| 5 football   | e | <input type="checkbox"/>            | track |
| 6 bike       | f | <input type="checkbox"/>            | bell  |
| 7 litter     | g | <input type="checkbox"/>            | hoop  |

## 2 Look at the pictures. Write the words.

1

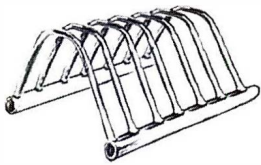

bike rack

2

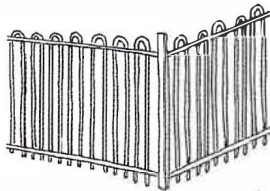

3

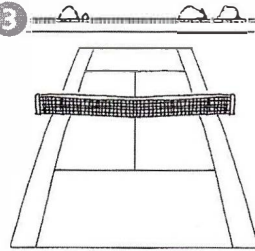

4



5

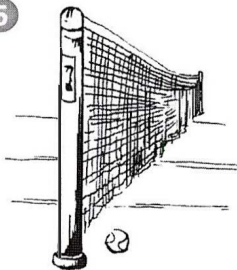

6

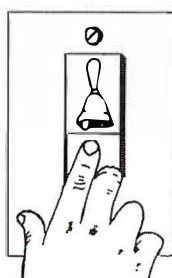

7



8

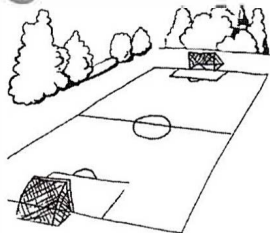

9

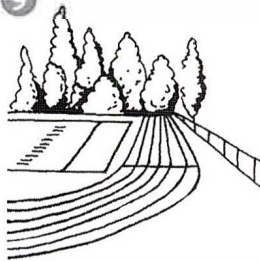

## 3 Complete the dialogue with the words from the box.

ask always strange  
Science idea day  
know Tuesday



**Patrick** So what lesson have we got now?

**Alex** I've no <sup>(1)</sup> idea. I don't even <sup>(2)</sup> what day it is.

**Phoebe** Neither do I. Look, there's Sam. Let's <sup>(3)</sup> her.

**Phoebe** Hi, Sam. What <sup>(4)</sup> is it today?

**Sam** It's <sup>(5)</sup>. Don't you know that?

**Alex** So we've got <sup>(6)</sup> with Mr Davis now.

**Sam** Yes, that's right. We <sup>(7)</sup> have Science on Tuesdays after lunch.

**Phoebe** Of course.

**Sam** You guys are <sup>(8)</sup> !



**1 Match the sentences from the box with the pictures.**

She's already got her new bike. They've already finished their treehouse.  
 He hasn't found the answer yet. ~~They haven't finished their treehouse yet.~~  
 He's already found the answer. She hasn't got her new bike yet.

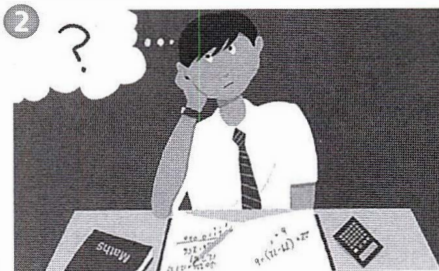

They haven't finished their treehouse yet.

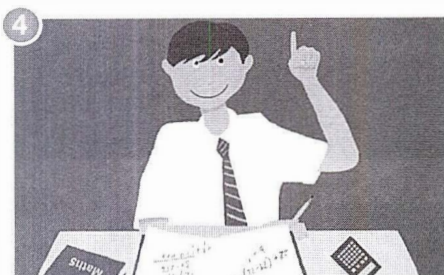

**2 Make sentences.**

- 1 breakfast / he's / had / already He's already had breakfast.
- 2 Linda / Brazil / been / yet / to / hasn't \_\_\_\_\_
- 3 asked / question / you've / that / already \_\_\_\_\_
- 4 haven't / yet / friend / his / I / met \_\_\_\_\_
- 5 we've / seen / that / already / film \_\_\_\_\_
- 6 homework / John / hasn't / yet / done / his \_\_\_\_\_

**3 Write questions.**

- 1 he / phone / Lisa yet?  
Has he phoned Lisa yet?
- 2 you / repair / your bike yet?  
 \_\_\_\_\_
- 3 they / walk / the dog yet?  
 \_\_\_\_\_
- 4 you / try / my cake yet?  
 \_\_\_\_\_
- 5 they / do / their homework yet?  
 \_\_\_\_\_
- 6 you / buy / my present yet?  
 \_\_\_\_\_



1 Remember the song. Complete it with the words from the box.

walked fast past where cross have time along talked lost been future

They've already <sup>(1)</sup> been to Pompeii  
 And seen fights in the old Wild West  
 And they've been <sup>(2)</sup> \_\_\_\_\_ at sea  
 On board the *Mary Celeste*.  
 They've already <sup>(3)</sup> \_\_\_\_\_ to Elvis  
 And had some cake in space.  
 They've <sup>(4)</sup> \_\_\_\_\_ in the rainforest -  
 A really amazing place!  
<sup>(5)</sup> \_\_\_\_\_ they been to Africa?  
 Will they go there? Yes or no?

Come <sup>(6)</sup> \_\_\_\_\_ and let's find out  
 The places <sup>(7)</sup> \_\_\_\_\_ they'll go.  
 The Time Travellers -  
 They're lost in <sup>(8)</sup> \_\_\_\_\_ .  
 They'll never come back  
 If they <sup>(9)</sup> \_\_\_\_\_ that line.  
 The Time Travellers -  
 Travelling so <sup>(10)</sup> \_\_\_\_\_ .  
 The <sup>(11)</sup> \_\_\_\_\_ is the present  
 And the <sup>(12)</sup> \_\_\_\_\_ is the past.

2 <sup>CD 1</sup> <sup>09</sup> Listen and say the words.

rain day cake

**Phonics tip**

Look for spelling patterns to help you say words. For example, *rain*, *day* and *cake* all have the same long vowel sound.

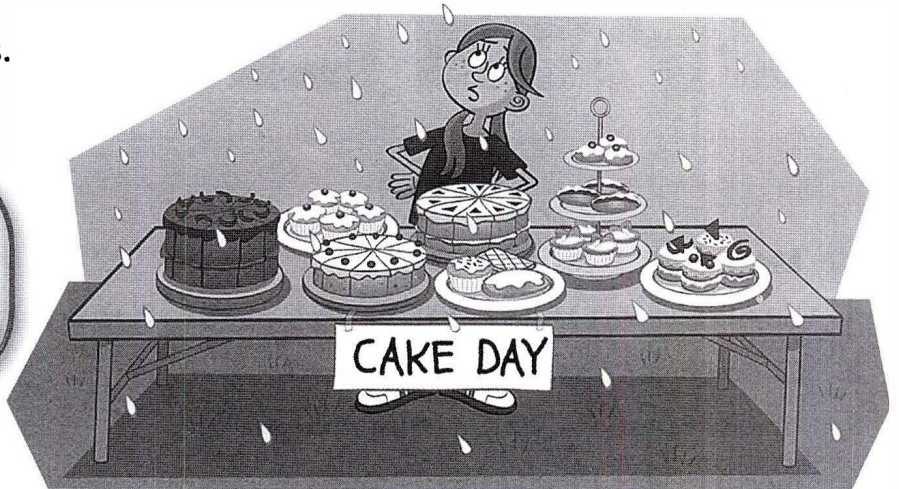

3 Say the words from the box and write them in the correct sound column.

rain team boat new table  
 learn right use time person  
 place piece key flies hole  
 gold blue surf

<b>say</b>	<b>see</b>	<b>my</b>
rain	team	
<b>know</b>	<b>too</b>	<b>bird</b>

4 <sup>CD 1</sup> <sup>10</sup> Listen, check and say the words.



**1 Look at the pictures. Write the words to complete the sentences.**

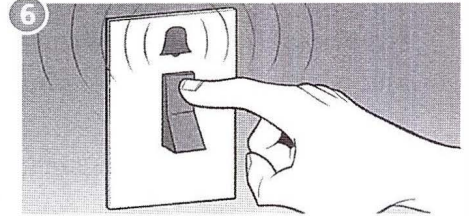
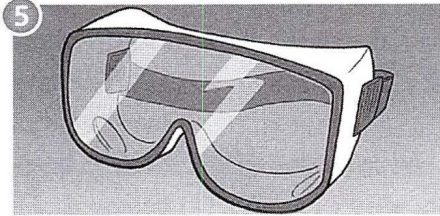
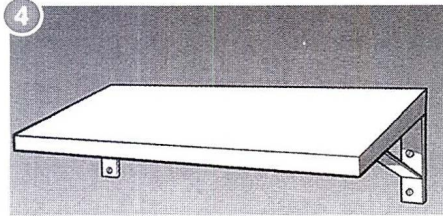
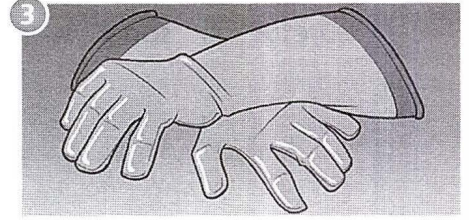
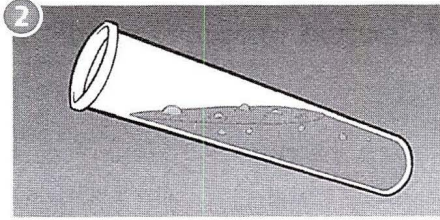
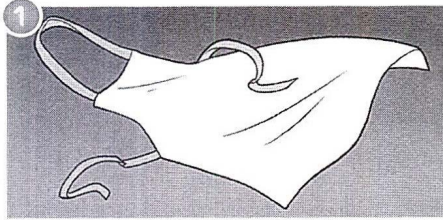

- 1 A cook is an example of someone who wears an apron for work.
- 2 \_\_\_\_\_ is a place where you mix things in a laboratory.
- 3 My coat pocket is the place where I keep my \_\_\_\_\_.
- 4 My model planes are the things which I keep on my bedroom \_\_\_\_\_.
- 5 \_\_\_\_\_ are the things which you wear to protect your eyes.
- 6 The headteacher is the person who rings the school \_\_\_\_\_.

**2 Complete the sentences with *which*, *who* or *where*.**

- 1 The running track is the place where we have our school sports day.
- 2 The Year 10 boys are the ones \_\_\_\_\_ spend all lunchtime on the football pitch.
- 3 The railings are the things \_\_\_\_\_ keep us from escaping!
- 4 The bike rack is the place \_\_\_\_\_ we leave our bikes.
- 5 Mrs Henderson is the lunchtime assistant \_\_\_\_\_ walks around the playground.
- 6 The basketball hoop is the thing \_\_\_\_\_ we try to jump up and touch.
- 7 The litter bin is the place \_\_\_\_\_ we throw away our crisp packets.
- 8 The school bell at the end of break is the thing \_\_\_\_\_ I hate most.

**3 Complete the sentences so that they are true for you.**

- 1 Football \_\_\_\_\_ is something which I enjoy.
- 2 \_\_\_\_\_ is the person \_\_\_\_\_ I spend most time with.
- 3 \_\_\_\_\_ is the place \_\_\_\_\_ I'd like to be now.
- 4 \_\_\_\_\_ is the singer \_\_\_\_\_ I like best.
- 5 \_\_\_\_\_ is the thing \_\_\_\_\_ I play with most.
- 6 \_\_\_\_\_ is the room \_\_\_\_\_ I spend most time at home.



**1 Remember the story. Choose five adjectives from the box to complete the summary.**

careful ill sorry worried excited ~~happy~~ bored hungry

The children go into the science lab. Patrick isn't <sup>(1)</sup> happy because he doesn't like Science. Alex and Phoebe think that something strange is happening. Then they see the date and it's the same date as when they started their adventures. Alex is <sup>(2)</sup> \_\_\_\_\_ that it is all going to happen again. Phoebe says that if they are <sup>(3)</sup> \_\_\_\_\_, they won't have an accident. They decide that Patrick can't help this time. Alex and Phoebe do all the same experiments again while Patrick just watches.

He is <sup>(4)</sup> \_\_\_\_\_ and he's fiddling with his goggles.

Mr Davis, the teacher, comes to talk to the children and he tells Patrick to put his goggles on. The goggles fly out of his hand and knock over a jar of powder on the shelf above the desk. The powder starts falling into the mixture below it. There is a big explosion and Patrick is <sup>(5)</sup> \_\_\_\_\_, but then the yellow light appears. The children know what they have to do and they walk through the gate.

**2 Complete the sentences with *which*, *who* or *where*.**

- 1 A lot of blue powder is the thing which causes the explosion.
- 2 Mr Davis is the man \_\_\_\_\_ teaches them Science.
- 3 Phoebe and Alex read the instructions \_\_\_\_\_ Mr Davis gave them.
- 4 The shelf is the place \_\_\_\_\_ the goggles hit the jar.
- 5 Patrick is the boy \_\_\_\_\_ causes the accident.
- 6 The science lab is the room \_\_\_\_\_ the accident happens.

**3 Think! Choose the best answer for each question.**

- 1 Why does Alex say 'This is strange?'
  - a Because of the date.
  - b Because the Science lesson seems the same.
- 2 Why does Phoebe say 'You're not going to do any of the experiments!' to Patrick?
  - a Because she doesn't want the accident to happen again.
  - b Because he's not very good at Science.
- 3 Why does Patrick say 'That's not fair!?'
  - a Because he really wants to do some experiments.
  - b Because he thinks the other two are being unkind to him.
- 4 Why does Phoebe say 'Sit there' to Patrick?
  - a Because she wants him far away from the experiment.
  - b Because she needs him to help her.
- 5 Why does Mr Davis say 'Excellent' to the children?
  - a Because they have done some really good work.
  - b Because they are working well.
- 6 Why does Phoebe shout 'What have you done??'
  - a Because she doesn't know what Patrick has done.
  - b Because she is angry with Patrick.



**1 Values** What can we learn from the story? Tick (✓).

- Don't put things on high shelves because they can cause accidents.
- Don't fiddle with things because you can cause accidents.
- Don't work with your friends because you'll have an accident.

**2** Write a true sentence for each picture from the story with the words from the box.

children / not / walk / into the light yet    ~~lesson / already / start~~  
 Patrick / not / knock / the powder over yet    blue powder / already / start / to fall

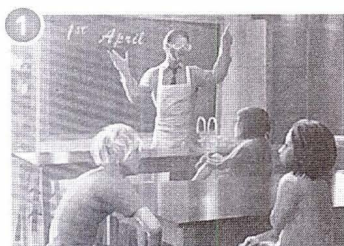

- 1 The lesson has already started.
- 2 \_\_\_\_\_
- 3 \_\_\_\_\_
- 4 \_\_\_\_\_

**3 Think!** Read and think about the situations. What do you think will happen? Complete the table with two ideas about each situation.

- 1 Patrick pretends to be ill. He goes to see the school nurse.
- 2 Patrick doesn't take off his goggles.
- 3 Patrick sits on a chair and doesn't move for the whole lesson.
- 4 Mr Davis puts Alex in a different group.

Your ideas	What happens?
1A The nurse gives him some medicine and sends him back to the classroom,	... so the explosion still happens.
2A _____	
3A _____	
4A _____	
1B The nurse sends him home,	... so the explosion doesn't happen.
2B _____	
3B _____	
4B _____	



# 1

# The treasure

1 Look at the pictures.  
Complete the words.

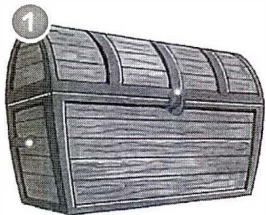

treasure  
chest



e \_ \_ -p \_ \_ ch

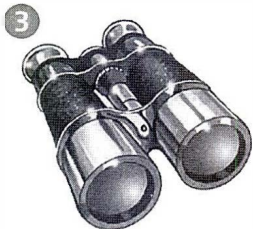

b \_ oc \_ \_ rs



p \_ m t \_ \_

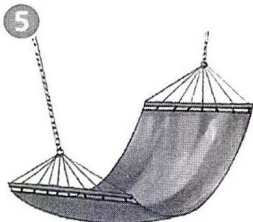

h \_ m \_ ck

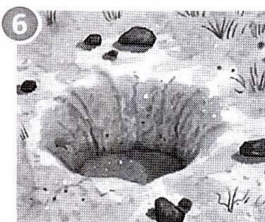

h \_ e



c \_ n \_



h \_ k



k \_ \_



s \_ d \_

2 Complete the crossword.

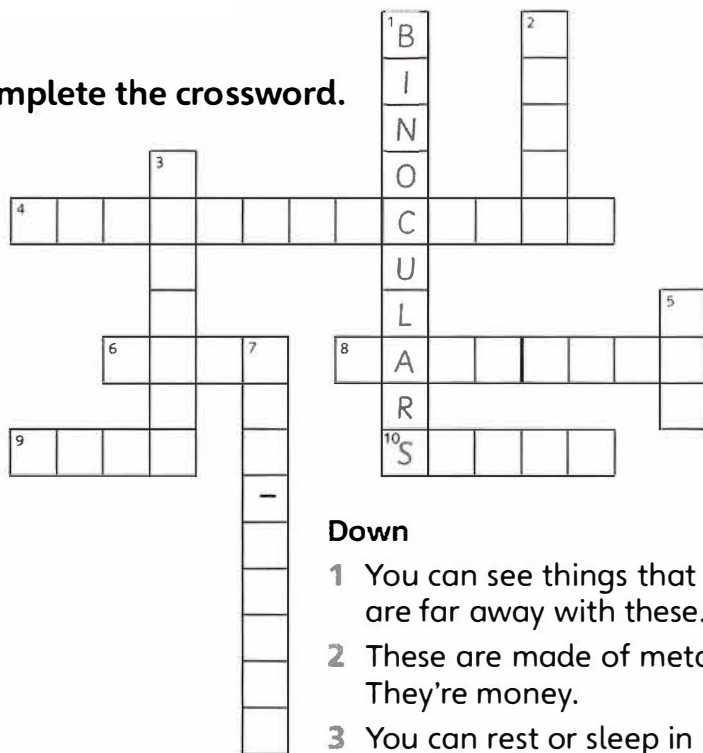

Down

- 1 You can see things that are far away with these.
- 2 These are made of metal. They're money.
- 3 You can rest or sleep in it.
- 5 You open doors (and treasure chests!) with it.
- 7 You wear it over one eye.

Across

- 4 There are gold coins in it.
- 6 It's in the ground.
- 8 You can climb it.
- 9 A pirate sometimes has this instead of a hand.
- 10 You dig holes with it.

3 Complete the sentences with the words from the box.

find bury dig wear pass put

- 1 Let's dig a hole here, next to the tree.
- 2 My uncle has to wear an eye-patch at the moment because he's had an accident.
- 3 Please pass me the spade. I'm going to plant this tree.
- 4 Let's bury the treasure chest on the beach, where the sand is soft.
- 5 Wow! Where did you find that old coin?
- 6 Dad, can I put up the hammock in the garden?



1 Complete the table with the phrases from the box.

eight o'clock six years March Tuesday three hours 2012  
 the sixteenth century twenty minutes last week five months  
 yesterday a day a long time eight weeks thirty seconds my birthday

for	since
	eight o'clock

2 Complete the sentences with *for* or *since*.

- I've had my bike *for* two years.
- I haven't had an email from Mia \_\_\_\_\_ the holidays.
- She hasn't visited her Mexican cousins \_\_\_\_\_ two years.
- He has known his friend Max \_\_\_\_\_ September.
- We haven't eaten anything \_\_\_\_\_ early this morning.
- I've known my friend Oscar \_\_\_\_\_ three years.

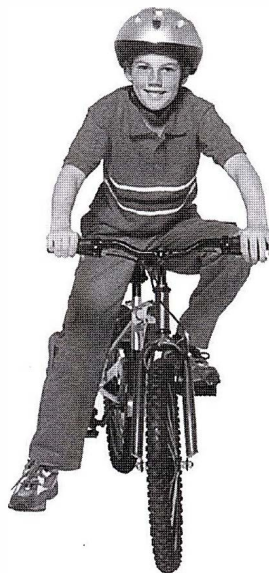

3 Write five sentences that are true for you with the verbs from the box.

play have live be interested in know

I've played football since I was seven.



**1 Remember the song. Complete the verbs and match the sentence halves.**

- |               |                            |  |
|---------------|----------------------------|--|
| 1 I've walked | a <input type="checkbox"/> | for gold and silver for years.             |
| 2 I've l_____ | b <input type="checkbox"/> | a lot of treasure.                         |
| 3 I've r_____ | c <input type="checkbox"/> | to say 'We're pirates' in three languages. |
| 4 I've f_____ | d <input type="checkbox"/> | lots and lots of ships.                    |
| 5 I've l_____ | e <input type="checkbox"/> | my parrot since she was an egg.            |
| 6 I've k_____ | f <input type="checkbox"/> | 1 around for years on a wooden leg.        |

**2 Correct the sentences.**

- |  |   |
|--|---|
| 1 The pirate's parrot is called Bonny.       | <u>The pirate's parrot is called Polly.</u> |
| 2 The pirates are in the Arctic.             | _____                                       |
| 3 He speaks German, French and Portuguese.   | _____                                       |
| 4 He's looked for horses and cows.           | _____                                       |
| 5 He's found a lot of treasure on mountains. | _____                                       |

**3 <sup>CD 1</sup> Listen and say the words.**

**mixture    treasure**

**Phonics tip**

Listen to these words. Can you hear the different sounds at the end of *mixture* and *treasure*?

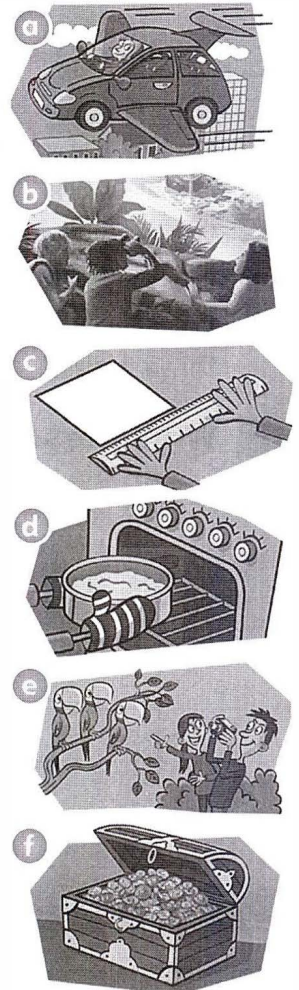

**4 Complete the sentences with the words from the box. Match them with the pictures.**

future    mixture    picture    treasure    adventure    measure

- Put the cake mixture in the pan. Then put it in the oven.
- Do you think cars will be able to fly in the \_\_\_\_\_?
- The pirate's \_\_\_\_\_ chest is full of gold coins.
- Let's take a \_\_\_\_\_ of the parrots.
- The three friends are travelling on an \_\_\_\_\_ through time.
- Use your ruler to \_\_\_\_\_ the square carefully.

d

**5 <sup>CD 1</sup> Listen, check and say the sentences.**



1 Ask people in your family about their favourite things. Write three sentences.

My mum's favourite thing is her ring. She's had it for fifteen years.

---



---



---

2 Look at the pictures. Write questions and answers.

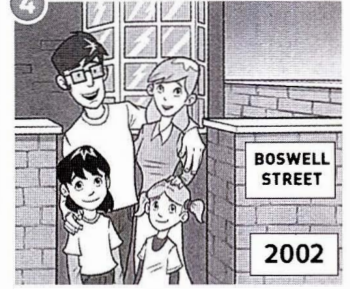
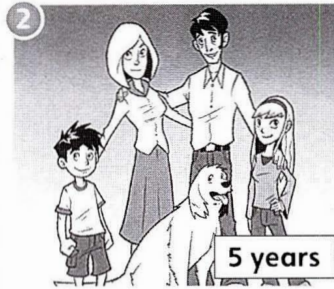

1 How long / Ava / be / at the supermarket?

How long has Ava been at the supermarket?

She's been at the supermarket since 10 o'clock.

2 How long / the Robinsons / have / their dog?

---

?

3 How long / Charlie / have / his computer game?

---

?

4 How long / the Carricks / live / in Boswell Street?

---

?

3 <sup>CD1</sup><sub>22</sub> Read and listen to the poem. Write your own poem.

How long have you had your old blue bike?

For five years, for five years.

How long have you had your old red ball?

Since I was seven, since I was seven.

How long have you had your old green cap?

Since I was six, since I was six.

OK, fine. Let's go into town.

You need new stuff. Let's go and buy it now.

---



---



---



---



---



---



---



---



---



---

**1 Remember the story. Put these objects from the text in order.**

a

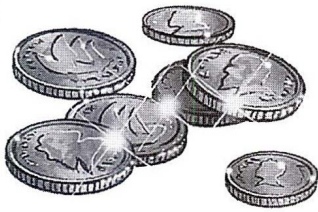

b

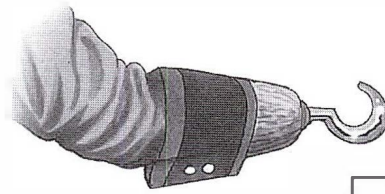

c

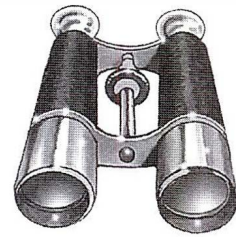

d

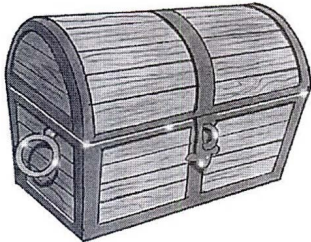

e

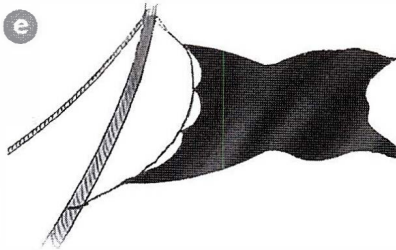

f

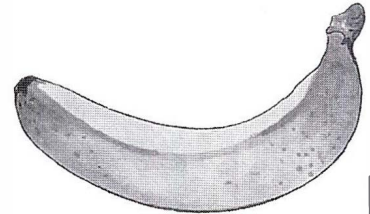







**2 Read the summary and correct six mistakes.**

Through their binoculars, the children watch the pirates sail away. They also see another ship with ~~green~~ sails and a black flag. When they look to the south, they see a bigger island with a town on it. Then they go to dig up the treasure. After three hours, they find the chest, which is full of gold coins. While they are deciding what to do with the treasure, they see some people with children arriving. They bring coconuts and talk to the people, who explain that the pirates have stolen their gold.

The children show them the treasure and give it back to them. They tell the people to go to the town on the other island. The people then leave. Later at night, five pirates and their prisoner arrive. They are looking for the treasure, but they only find a big hole. Patrick sneezes and the pirates find the children. The pirates want to know where the chest has gone and they threaten to throw the children into the sea. Then the light appears in the hole so the children jump in and escape.

a ship with red sails,

**3 Match the questions with the answers.**

- 1 Why did the children run to see the people in the boat?
- 2 Why did the children hide from the people shouting?
- 3 Where was the ship with the black flag going to?
- 4 Where was the island with the town on it?
- 5 When did the children drink some coconut milk?
- 6 When did Phoebe and Patrick start arguing?
- 7 What did the children give the people?
- 8 What did the children give the pirates?

- a  The north.
- b  Before they dug the hole.
- c  The treasure chest.
- d  Nothing!
- e  1 Because they weren't pirates.
- f  The south.
- g  After they dug the hole.
- h  Because they were pirates.



**1 Think!** Write the events from the box next to the times when they happen.

The children go to sleep. The pirates finish and leave the island.  
 The children welcome the families to the island. The children find the treasure.  
 The children jump into the hole. The children start digging for the treasure.  
 The children hear shouting. The children watch the pirates burying the treasure.  
 The children say goodbye to the families. ~~The children arrive on the island.~~

8.45 a.m	<i>The children arrive on the island.</i>
9 a.m.	
10 a.m.	
11 a.m.	
1 p.m.	
1.30 p.m.	
3.30 p.m.	
8 p.m.	
Midnight	
12.15 a.m.	

**2 Think!** Read and complete the time phrases. Use the information from Activity 1.

- |   |  |  |
|---|--|--|
| <p>1 It's 9.45 a.m. The pirates have been at the hole ...<br/>for <u>45 minutes</u><br/>since <u>9 a.m.</u></p> | <p>3 It's 1.15 p.m. The children have had the treasure ...<br/>for _____<br/>since _____</p> | <p>5 It's 7.45 p.m. They have been on the island ...<br/>for _____<br/>since _____</p>   |
| <p>2 It's 11.25 a.m. The children haven't seen the pirates ...<br/>for _____<br/>since _____</p>                | <p>4 It's 3.05 p.m. They have been with the families ...<br/>for _____<br/>since _____</p>   | <p>6 It's 11.55 p.m. The children have been asleep ...<br/>for _____<br/>since _____</p> |

**3 Values** Imagine that the families don't come to the island. What should the children do with the treasure? Write *b* (best), *o* (OK) and *w* (worst) next to the three ideas. Think of two more good ideas.

- |   |                          |
|---|--------------------------|
| 1 Leave it on the island.                         | <input type="checkbox"/> |
| 2 Keep it and spend it on toys, sweets and games. | <input type="checkbox"/> |
| 3 Give it to the local hospital.                  | <input type="checkbox"/> |

**1** Read the text on Student's Book page 16 again. Complete the questions.

- 1 What is the Roman helmet made of?
- 2 \_\_\_\_\_ found it?
- 3 \_\_\_\_\_ is the helmet worth so much money?
- 4 \_\_\_\_\_ does the helmet look like?
- 5 \_\_\_\_\_ do the experts think that people wore the helmet?
- 6 \_\_\_\_\_ of the money do people usually get when a museum buys an object?

**2** Match the questions from Activity 1 with the answers.

- a  An Englishman who was searching in his garden with a metal detector.
- b  It's a face mask with a cap, and there's a lion with the wings of an eagle on it.
- c  1 It's made of copper.
- d  They get half of the price that it sells for.
- e  It looks beautiful and only two other helmets like this one exist.
- f  They think that the soldier who owned the helmet only wore it for parades.

**3** Put the dialogue in order.

- A Because our neighbour found a gold necklace on the beach with a metal detector.
- A He reported his find to a big museum.
- A It wasn't! It was the honest thing to do. They gave him £5,000.
- A Right! Let's go together!
- 1 A I'm thinking of buying a metal detector.
- A Why? Where are you going?
- B How silly of him!
- B With a metal detector? Wow! And what did he do with the necklace?
- B Really? Right, I've got to go. I'm in a hurry.
- B To the shops. I'm going to buy a metal detector too.
- B Why would you like to do that?

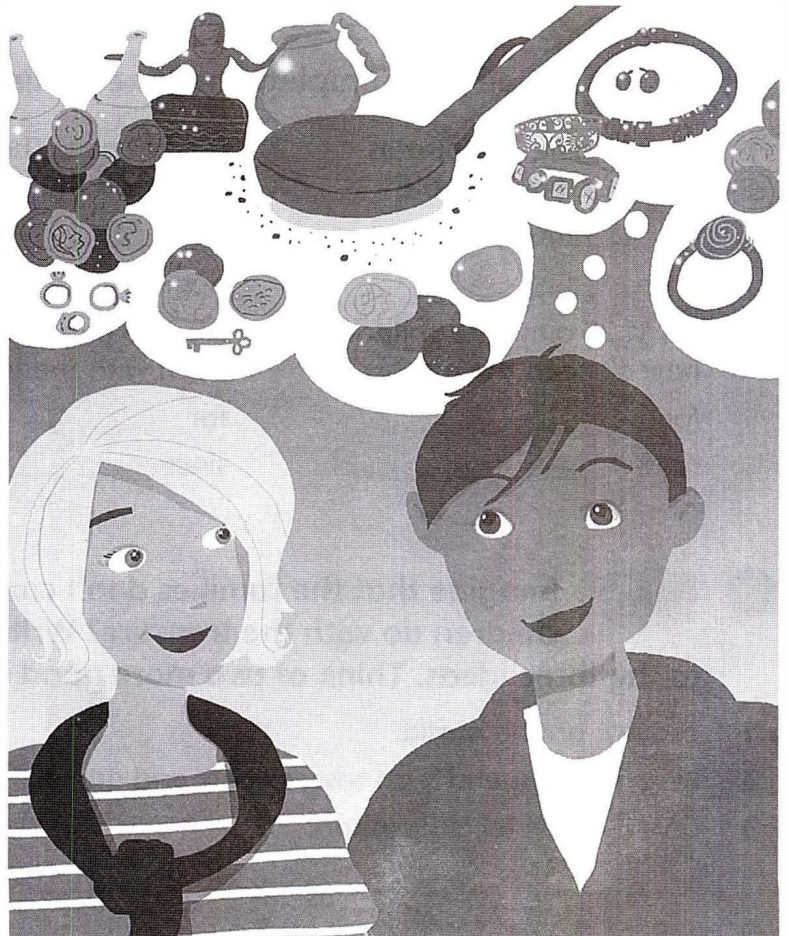



**1 Work with a partner. Choose a role card and act out a conversation.**

Student A

You see Student B outside with a metal detector. Ask:

- what the metal detector does
- for the price and where B bought it
- if B uses it a lot and if B likes it
- what B has found already

Student B

- You got a metal detector a week ago. It was a birthday present.
- You really like it and you go out every afternoon to look for old things in the ground.
- You've already found an old bike and a pair of broken sunglasses.

**2 Values What should you do when you find something?  
Colour a word in each column to make a sentence.**

a metal detector	never show	garden	hide it	village.
Roman helmets	report	and tell	take it to	find.
You should always	beaches	experts	museum	a museum.
the police	golden	the find and	mustn't keep it	had.

**3 Complete the five conversations. Choose A, B or C.**

1 Guess what! I found a golden bracelet.

A I hope so too.

**B** Really? How exciting!

C I want it too.

2 Can you show me your metal detector?

A It's expensive.

B You're welcome.

C Yes, sure.

3 How long is Dad going to be away?

A It took three months.

B For two weeks.

C Since last month.

4 I'm sorry I can't tell you the price.

A What a pity!

B I hope so.

C I'll take two.

5 I don't like your suggestion.

A OK, let's make it then.

B I didn't like it.

C OK, let's think of a better idea.

مرجع زبان ایرانیان

1 Match the pictures with the words and phrases.

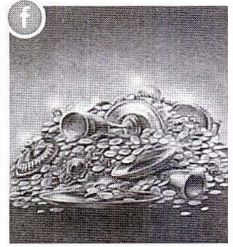
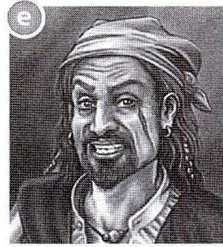
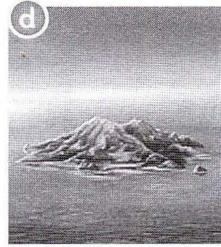
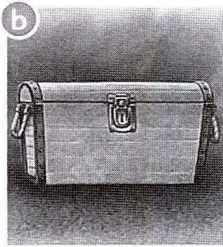
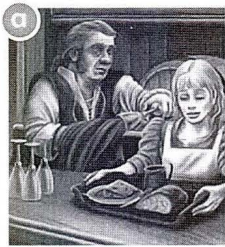

- 1 an island  d      3 a sea-chest       5 an inn
- 2 treasure       4 a man with a scar       6 a man with a pigtail

2 Read the book forum and answer the questions.

◀ ▶ 🏠 ↻ 🔍

**What I'm reading now ...**

My name's Cathy Carlisle. I'm in Year 6. We're reading *Treasure Island* at school. It's a great book. We haven't finished it yet, but I can't wait to see what's coming next. We're also learning about oceans, ocean animals, how to read maps, pirates and lots more. Learning a lot of interesting facts helps me to understand the book really well.

Hello everyone from Cindy, in NY. We've just finished reading *Treasure Island* in my class. I liked it a lot. My favourite character in the story is Jim because he's an honest person and he keeps his promises. I loved reading it.

Hi, I'm Tom Whitney. One of the books which we're reading this year at school is *Treasure Island*. We're having a lot of fun reading this book. I like it because it's full of adventures. My favourite character is Ben Gunn because he survived on the island for three years. We have two more parts to read and I can't wait to see what happens.

I'm Michael Prowse. I think *Treasure Island* is an amazing book. I've got three favourite characters: Jim Hawkins, Ben Gunn and Long John Silver with his parrot. (I love the parrot too!) I've read the book and I've also seen the film *Treasure Island*. I like them both the same.

- 1 What kind of texts have the four students written? reviews
- 2 What is different about Tom and Michael's texts? What is the same?  
\_\_\_\_\_
- 3 Who is doing a project about topics that are related to *Treasure Island*?  
\_\_\_\_\_
- 4 What is the same about Cathy and Tom's texts?  
\_\_\_\_\_
- 5 Who has seen the film and read the book? Which does he/she prefer?  
\_\_\_\_\_
- 6 Who writes about people who they like in *Treasure Island*?  
\_\_\_\_\_



1 Correct the sentences.

- 1 The pirate in *Treasure Island* is called Captain Hook.  
No, he isn't called Captain Hook. He's called Long John Silver.
- 2 Stevenson got the idea for the book when he drew a ship for a friend's son.
- 3 He wrote a story in several episodes called *The Sea-Cook* for a newspaper.
- 4 The story was a success at first.
- 5 Later, he published the story as a book with the same title as the story.
- 6 *Treasure Island* made William Shakespeare really famous.

2 Write a story about a pirate. Use these ideas to help you or your own ideas.

**Create the characters in your story.**

- Who is the main pirate character?  
(What is his/her name? What does he/she look like?  
Has he/she got an animal? What kind of person is he/she?  
What clothes does he/she usually wear?)
- Who are the other characters in the story?  
(What are their names? What do they look like?  
What kind of people are they?  
What clothes do they usually wear?)

**Find the place(s) for your story.**

- Where does the story take place?  
(On an island? In the middle of an ocean?  
In a big harbour? On a big ship?)

**What happens?**

- What are the pirate's plans?
- What do they do? What happens?
- Does the story have a happy ending?

□ ■ A I A ● ● ●

Captain Whitepatch was a good pirate. He ...

- 1** Make three sentences with the phrases in the diamond.  
Use three different phrases in each sentence.

I've known \_\_\_\_\_  
 \_\_\_\_\_  
 \_\_\_\_\_  
 \_\_\_\_\_  
 \_\_\_\_\_



- 2** Draw lines and complete the sentences with the words from the box.

since I long have seen Sue in your for eight mum has

1 We've lived _____	worked at the _____	for eight _____ years.
2 I've had _____	you known _____	was six.
3 My _____	in London _____	hospital since 1998.
4 Tom hasn't _____	my dog _____	Mr Lester?
5 How _____	has Mary lived _____	six months.
6 How long _____	_____ for _____	_____ street?

- 3** Complete the sentences with your own ideas.

- I've known \_\_\_\_\_ .
- \_\_\_\_\_ for a year.
- How long have \_\_\_\_\_ ?
- She's lived \_\_\_\_\_ .
- \_\_\_\_\_ since last December.
- How long has \_\_\_\_\_ ?





# 2

# Future transport

1 Find eight travel words. Draw lines to the eight correct pictures.



r	f	i	n	l	i	n	e	s	k	a	t	e	s
s	d	a	g	b	j	i	o	k	l	c	v	t	o
m	l	h	m	o	n	o	r	a	i	l	m	t	l
d	p	a	r	a	c	h	u	t	e	z	i	h	e
c	y	n	g	i	w	y	x	l	d	u	c	e	t
b	w	g	r	s	u	r	f	b	o	a	r	d	x
u	j	g	c	e	a	f	r	y	r	e	o	s	a
o	k	l	g	j	e	t	p	a	c	k	l	w	s
u	n	i	c	y	c	l	e	r	j	k	i	r	u
h	k	d	x	s	h	u	k	z	n	l	g	f	l
l	s	e	c	a	b	l	e	c	a	r	h	n	o
g	z	r	v	z	s	d	s	t	b	a	t	s	t

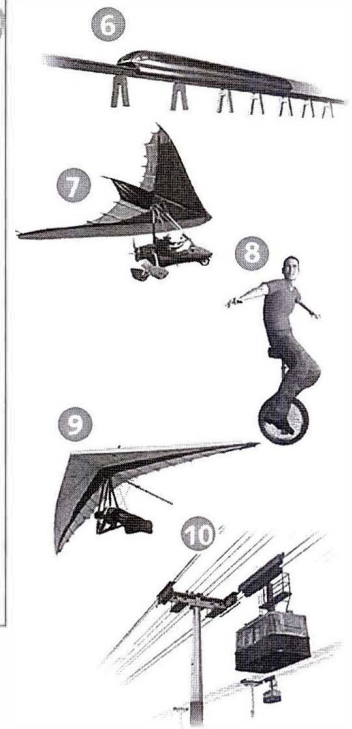

2 Complete the table.

Transport gadgets	for one person in the air	floating skateboard
	for one person on the ground or water	_____
	for more than one person	_____
Gadgets that make energy		_____

3 Complete the sentences with the words from the box.

monorail surfboard unicycle parachute jet pack cable car

- My uncle works in a circus. He rides a unicycle and juggles balls.
- Can you buy a \_\_\_\_\_ or do they only exist in films?
- He jumped from the plane and opened his \_\_\_\_\_.
- Take the \_\_\_\_\_ direct from the airport. It's the quickest way into the city.
- You can get to the top of the mountain in three hours or in ten minutes by \_\_\_\_\_.
- The shark took a big bite out of his \_\_\_\_\_.



1 Look at the adverts. What do you need to bring for each expedition?

Join our 2-day walking safari in South Africa's Kruger Park!

Bring:



For the greatest adventure, join our 2-day cave trip in Mexico!

Bring:





- 1 For the walking safari, you need to bring a hat, \_\_\_\_\_
- 2 For the cave trip, \_\_\_\_\_

2 Complete the sentences with *need to* or *don't need to*.

- 1 We leave at six. You need to be at school at ten to six.
- 2 You \_\_\_\_\_ call Lucy. I've already called her.
- 3 You \_\_\_\_\_ bring any snacks with you. We'll have lunch at a restaurant.
- 4 You're cold, aren't you? You \_\_\_\_\_ wear a thicker jumper.
- 5 You \_\_\_\_\_ do the washing up. We've got a dishwasher.
- 6 I feel sick. I \_\_\_\_\_ go to the bathroom.
- 7 The fridge is empty. We \_\_\_\_\_ do some shopping.
- 8 You \_\_\_\_\_ help your brother. He can't do his homework and I don't speak German.

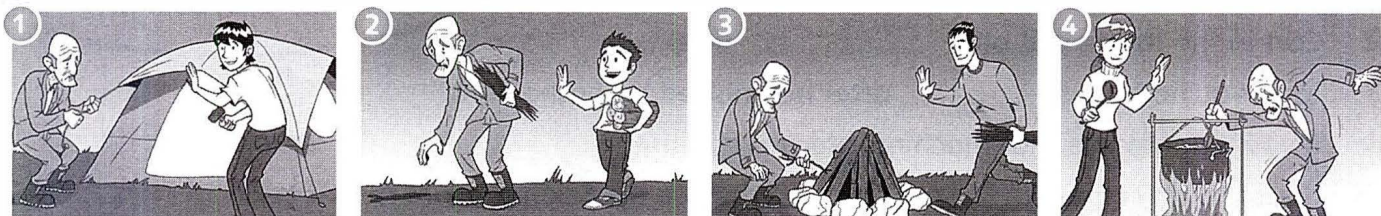
3 Write a sentence for each picture.



- 1 It's OK, Grandpa. You don't need to put up the tent. I'll do it for you.
- 2 \_\_\_\_\_
- 3 \_\_\_\_\_
- 4 \_\_\_\_\_

**1 Complete the dialogue with the words from the box.**

ask ride need it's hate matter silly wearing

**Charlie** Are you going to <sup>(1)</sup> ride your bike, Olivia?

**Olivia** Yes, sure. Why do you <sup>(2)</sup> \_\_\_\_\_ ?

**Charlie** Well, why aren't you <sup>(3)</sup> \_\_\_\_\_ a helmet?

**Olivia** I don't <sup>(4)</sup> \_\_\_\_\_ to wear a helmet.

**Charlie** You should wear one. <sup>(5)</sup> \_\_\_\_\_ dangerous on the road.

**Olivia** Don't be silly. I <sup>(6)</sup> \_\_\_\_\_ helmets.

**Charlie** Why? I don't understand.

**Olivia** I look <sup>(7)</sup> \_\_\_\_\_ in a helmet.

**Charlie** That doesn't <sup>(8)</sup> \_\_\_\_\_. You still need to be safe.

**2** CD 1  
31 **Listen and say the words.**

**television station profession**

**Phonics tip**

The *-ion* syllable isn't stressed, so it has a short vowel sound. Most words ending in *-sion* have the same sound as in *television*. Most words ending in *-tion* or *-ssion* have the *sh* sound.



**3 Complete the sentences with the words from the box.**

instructions ~~station~~ explosion emission  
television pollution revision invitation

- 1 I went to the station to catch the 9 o'clock train.
- 2 Cars in the future will be \_\_\_\_\_-free.
- 3 Jack watched \_\_\_\_\_ after he finished his homework.
- 4 If you want to use that machine, please read the \_\_\_\_\_ carefully.
- 5 I need to do some \_\_\_\_\_ before the Science exam next week.
- 6 Julie gave me an \_\_\_\_\_ to her birthday party on Saturday.
- 7 If you mix those powders together, you'll cause an \_\_\_\_\_.
- 8 There's a lot of \_\_\_\_\_ in big cities.

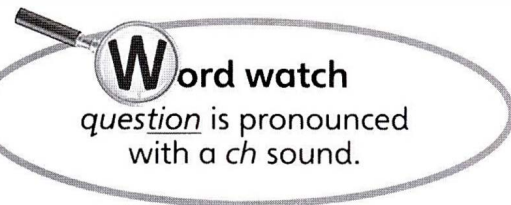

**4** CD 1  
32 **Listen, check and say the sentences.**



**1 Make sentences.**

- 1 will / trees / cities / be / in / there / lots / of / our *There will be lots of trees in our cities.*
- 2 there / any / cars / won't / be / drivers / with \_\_\_\_\_
- 3 of / cities / most / have / will / our / monorails \_\_\_\_\_
- 4 won't / car / be / any / accidents / there \_\_\_\_\_
- 5 people / in / eat / fast / restaurants / will / pills / food \_\_\_\_\_
- 6 will / people / more / have / play / time / to \_\_\_\_\_

**2 What will the world be like in 2050? Look at the pictures and write sentences.**

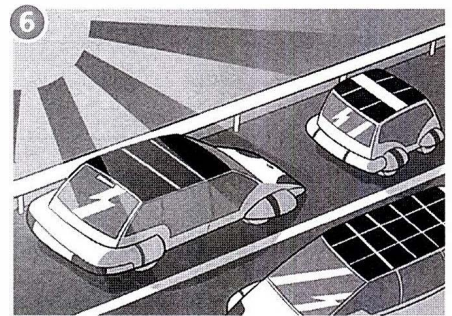
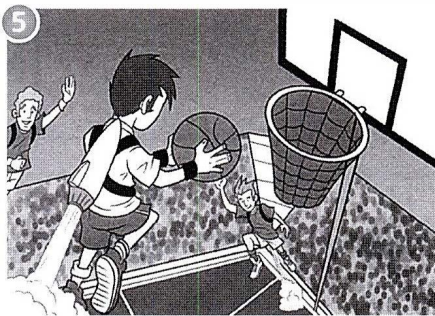
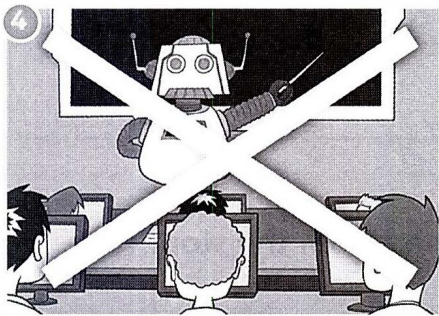
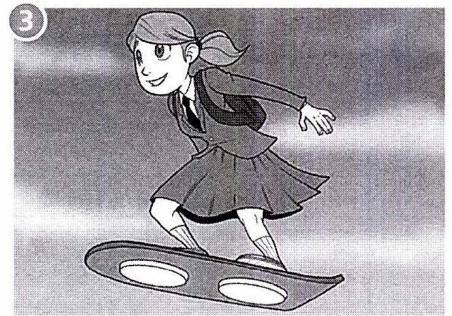
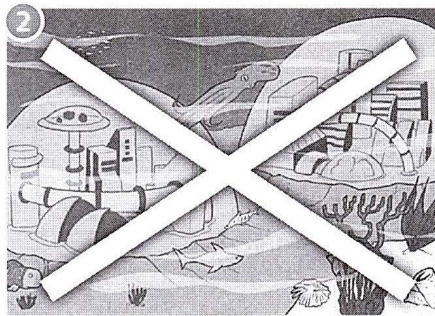
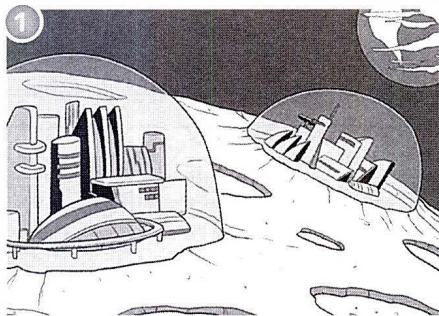

- 1 There will be *cities on the moon* \_\_\_\_\_
- 2 There won't be \_\_\_\_\_
- 3 Children \_\_\_\_\_
- 4 Students \_\_\_\_\_
- 5 Children \_\_\_\_\_
- 6 Cars \_\_\_\_\_

**3 What do you think? What will the world be like in 2050? Write three sentences with *will* / *won't*.**

**1 Think!** Remember the story. Put the sentences in order.

- Patrick's parachute opens.
- Phoebe and Alex shout instructions to Patrick.
- Phoebe and Alex fly around the mountain.
- They fly over the park and towards the sea.
- The man congratulates Patrick on good flying.
- 1 Phoebe and Alex read the instructions carefully.
- Phoebe starts to get worried about Patrick.
- They see Patrick falling through the sky.

**2** Complete the table.

Who?	How do they feel?	When?
(1) <i>Phoebe and Alex</i>	(2) <i>nervous</i>	they listen to the instructions.
(3) _____	excited	(4) _____
(5) _____	(6) _____	she can't see Patrick anywhere.
(7) _____	scared	(8) _____

**3** Complete the jet pack instructions with the correct colours from the story.

## Congratulations on buying the Flyme X2000!

Before you take to the skies, please take the time to read and remember:

To take off, press the <sup>(1)</sup> *yellow* button.

To go higher, press the <sup>(2)</sup> \_\_\_\_\_ button.

To go faster, press the <sup>(3)</sup> \_\_\_\_\_ button.

To go down, press the <sup>(4)</sup> \_\_\_\_\_ button.

To open the parachute, press the <sup>(5)</sup> \_\_\_\_\_

and the <sup>(6)</sup> \_\_\_\_\_ buttons together.

**Fly safely and enjoy yourself!**

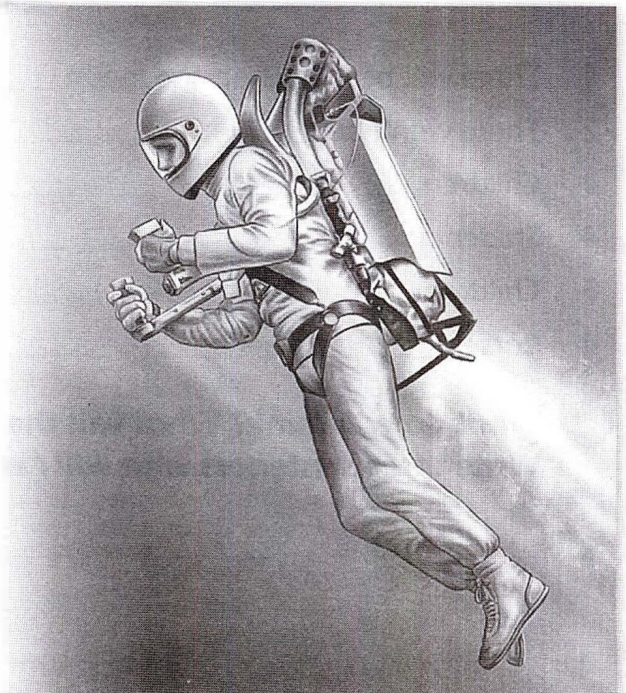



**1 Think!** Read the sentences. Complete the information on the sign.

- 1 You need to be 17 to hire the most expensive thing.
- 2 Floating skateboards cost £5 an hour.
- 3 Inline skates are £7 cheaper than surfboards.
- 4 You can rent floating skateboards and surfboards at the same age.
- 5 If you are 9, the only things you can hire are inline skates.
- 6 You need to be 13 to hire the things that cost £15 an hour.
- 7 Unicycles are three times more expensive than inline skates.
- 8 Microlights cost £15 more than inline skates.
- 9 A 9-year-old needs to be two years older to hire floating skateboards.
- 10 Surfboards cost £12 an hour.

## For hire

- ★ Microlights: £ <sup>(1)</sup> \_\_\_\_\_ an hour  
(minimum age <sup>(2)</sup> \_\_\_\_\_)
- ★ Floating skateboards: £ <sup>(3)</sup> 5 \_\_\_\_\_ an hour  
(minimum age <sup>(4)</sup> \_\_\_\_\_)
- ★ Unicycles: £ <sup>(5)</sup> \_\_\_\_\_ an hour  
(minimum age <sup>(6)</sup> \_\_\_\_\_)
- ★ Inline skates: £ <sup>(7)</sup> \_\_\_\_\_ an hour  
(minimum age <sup>(8)</sup> \_\_\_\_\_)
- ★ Surfboards: £ <sup>(9)</sup> \_\_\_\_\_ an hour  
(minimum age <sup>(10)</sup> \_\_\_\_\_)

**2 Values** Look at the pictures. Complete the sentences.

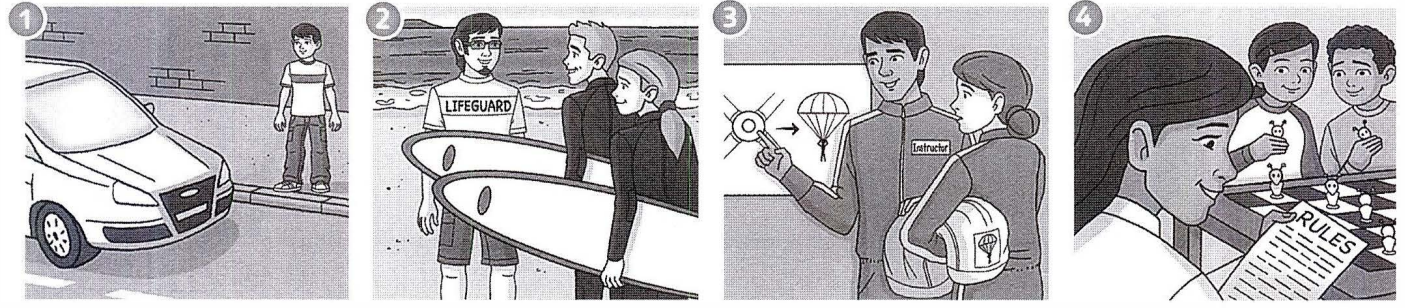

- 1 He needs to look and listen carefully before he crosses the road \_\_\_\_\_.
- 2 They need to \_\_\_\_\_.
- 3 She needs to \_\_\_\_\_.
- 4 They need to \_\_\_\_\_.

**3 Values** Write about two more situations when you need to listen carefully.

	You need to listen carefully when your teacher gives you homework so you'll know what to do.

Listen to five short conversations. Tick (✓) the right answer.



1 Where did Brenda's family go on holiday last year?

 Spain	 Turkey	 Italy
A <input type="checkbox"/>	B <input checked="" type="checkbox"/>	C <input type="checkbox"/>

2 How many postcards did the man buy?

7	14	40
A <input type="checkbox"/>	B <input type="checkbox"/>	C <input type="checkbox"/>

3 What time does Sue's piano lesson start?

		
A <input type="checkbox"/>	B <input type="checkbox"/>	C <input type="checkbox"/>

4 How far is Jane's nearest train station?

		
A <input type="checkbox"/>	B <input type="checkbox"/>	C <input type="checkbox"/>

5 What will the weather be like?

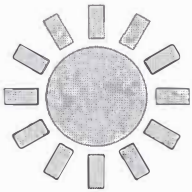
		
A <input type="checkbox"/>	B <input type="checkbox"/>	C <input type="checkbox"/>



1 Work in pairs. Student A: Here is some information about a museum. Student B: You don't know about the museum. Ask and answer questions.

**Student A**

Almost 100 cars to look at

OPEN

Mon-Fri 2 p.m.-6 p.m.  
Sat and Sun 9 a.m.-5 p.m.

Visit our shop: books, posters, postcards  
Large car park (free)  
Tickets: Adults £12  
Students £7

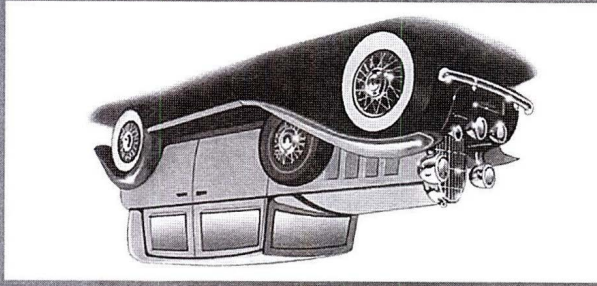

**BRIGHTON CAR MUSEUM**

**Student B**

**MUSEUM**

- what / see?
- open / weekends?
- student ticket / £?
- car park?
- buy posters?

2 Which notice (A-H) says this (1-6)? Write the correct letter.

- You should not play football here.  E
- You can use the monorail again at the weekend.
- You must not make any noise here.
- You can buy things on Sundays here.
- It's less expensive to fly the next day.
- You must not walk your pet here.

- A Open Monday-Friday  
Closed at weekends
- B Shop now open all week
- C Closed until the weekend  
Then open again
- D  **HALF PRICE**  
Microlight hire tomorrow
- E **NO GAMES IN THESE FIELDS**
- F No dogs in the park  
No skateboards
- G Please be **QUIET**  
in the library
- H **PLAYING FOOTBALL ALLOWED HERE**

**1 Match the words from the box with the pictures.**

cart factory carriage cannon engine

1



2



3

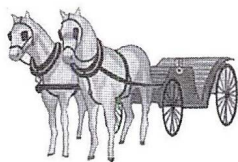

4

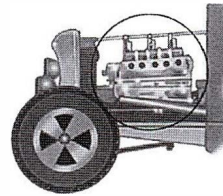

5

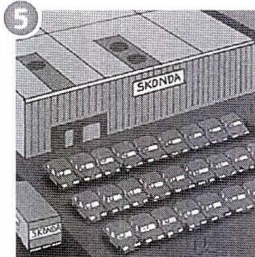

cannon

**2 Read the text on Student's Book pages 30 and 31 again. Write t (true), f (false) or ds (doesn't say).**

- 1 Nicolas Cugnot's cart had three engines.
- 2 Four horses pulled the Puffing Devil.
- 3 There has been a speed limit for over 140 years.
- 4 In 1865, the speed limit in the countryside was double the speed limit in towns.
- 5 The first car accident was at the end of the last century.
- 6 Bridget Driscoll was on her way to work when she died.
- 7 It took just over an hour and a half to build a Model Ford T.
- 8 European governments passed pollution laws in 1965.

f

**3 Values Match the sentences with the pictures.**

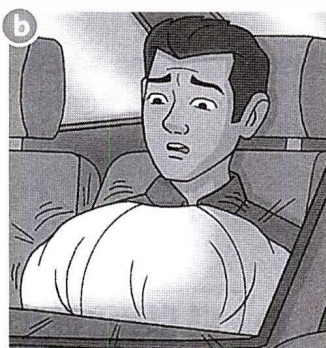
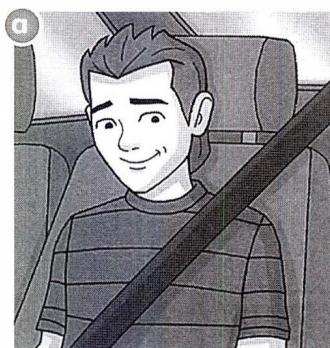

- 1 Everyone should wear a seatbelt.
- 2 All children in the UK under 135 cm must use a special child car seat.
- 3 The seatbelt should fit you perfectly.
- 4 Airbags save lives, but remember that they can hurt you if they inflate and you aren't wearing your seatbelt.

d



**1 Read about three famous cars. Write the names of the cars under the photos.**

*Knight Rider* was a very popular American TV series from the early 1980s. It followed the adventures of Michael Knight, a special police officer fighting crime in Las Vegas. However, for many of its fans, the real star of the show was Michael's partner, a super-fast black American sports car called KITT. A computer controlled KITT and KITT talked to Michael, explaining how to fight the baddies, and he was always there to save Michael when things were difficult. KITT was also very strong and almost impossible to destroy.

Herbie was a white VW Beetle with blue and red racing stripes and the number 53 on his bonnet. He loved racing, but what made Herbie special was that he could think for himself and he could make his own decisions. Although he had a driver, he didn't really need one because he could drive himself. Herbie made his first appearance in cinemas in the 1968 film *The Love Bug*. Since then, he has made audiences laugh in five more films and he also had his own television series too.

*Chitty Chitty Bang Bang* is a 1968 children's musical film about an inventor called Caractacus Potts who lives with his two children, Jeremy and Jemima. One day, they find an old racing car and their father decides to rebuild the car and turn it into something very special. The result is Chitty Chitty Bang Bang, a car which can float on water and, even more amazingly, a car which can fly. Chitty Chitty Bang Bang then takes the Potts family on an incredible adventure and even helps Caractacus to find love.

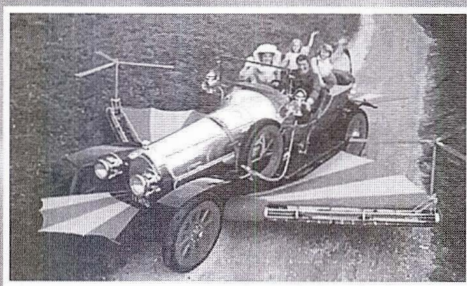

1 \_\_\_\_\_

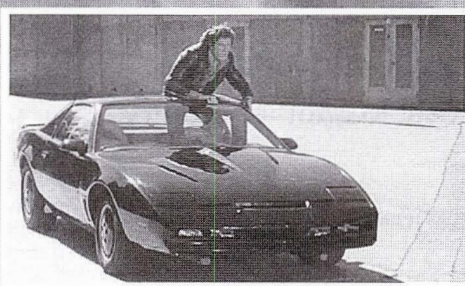

2 \_\_\_\_\_



3 \_\_\_\_\_

**2 Read the text again and complete the table.**

	Film, TV or both?	What's special about this car?
KITT	(1) TV _____	(2) _____
Herbie	(3) _____	(4) _____
Chitty Chitty Bang Bang	(5) _____	(6) _____

**3 Write about your favourite car (a real car, one from a film or TV or an imaginary one).**

□ ■ A I A

● ● ●

My favourite car is ...

**1 Choose six words or phrases to complete the sentences.**

don't need to	1	There will	be cities under the sea one day.	you don't
need to wear	2	People	bikes in the future.	you will
<del>There will</del>	3	I	famous when I'm 20.	will be
don't need	4	You	a helmet on a motorbike.	need to
to be	5	You	buy a ticket. I've got an extra one.	won't ride
	6	You need	careful in the jungle. There are snakes there.	

**2 There is a word missing from these sentences. Write each sentence with a word from the box in the correct place.**

don't   won't   to   will   need   use

- 1 There be too many cars in the world soon.  
There will be too many cars in the world soon.
- 2 You to take a passport to travel to another country.
- 3 Don't worry. The exam be difficult.
- 4 Everyone will solar panels for energy one day.
- 5 You need to say sorry. It wasn't your fault.
- 6 I want a new computer. I need talk to Dad.

**3 Complete the sentences with your own ideas.**

- 1 There will \_\_\_\_\_.
- 2 \_\_\_\_\_ in the future.
- 3 I won't \_\_\_\_\_.
- 4 It's cold outside. You need \_\_\_\_\_.
- 5 You don't \_\_\_\_\_ . I've already done it.
- 6 Go to bed. You need \_\_\_\_\_.



1 Find and write the words.

surf pa in  
 skates la mo  
 rail en line  
 gon board chute  
 ra no do gine

surfboard  
 \_\_\_\_\_  
 \_\_\_\_\_  
 \_\_\_\_\_  
 \_\_\_\_\_

2 Complete the sentences with the words from Activity 1.

- 1 Our car needed a new engine , so Mum and Dad decided to buy a new car instead!
- 2 You must be good at swimming if you want to take a \_\_\_\_\_ into the sea.
- 3 When are they going to build a \_\_\_\_\_ in our city?
- 4 Patrick pressed the two buttons and opened his \_\_\_\_\_ .
- 5 We went on a \_\_\_\_\_ and Dad nearly fell into the water!
- 6 I had some \_\_\_\_\_ for my birthday.

3 Write about school life in 2100. Think about the points below.

- what the lessons will be like
- what the teacher will be like
- what you will still need to do
- what you won't need to do any more

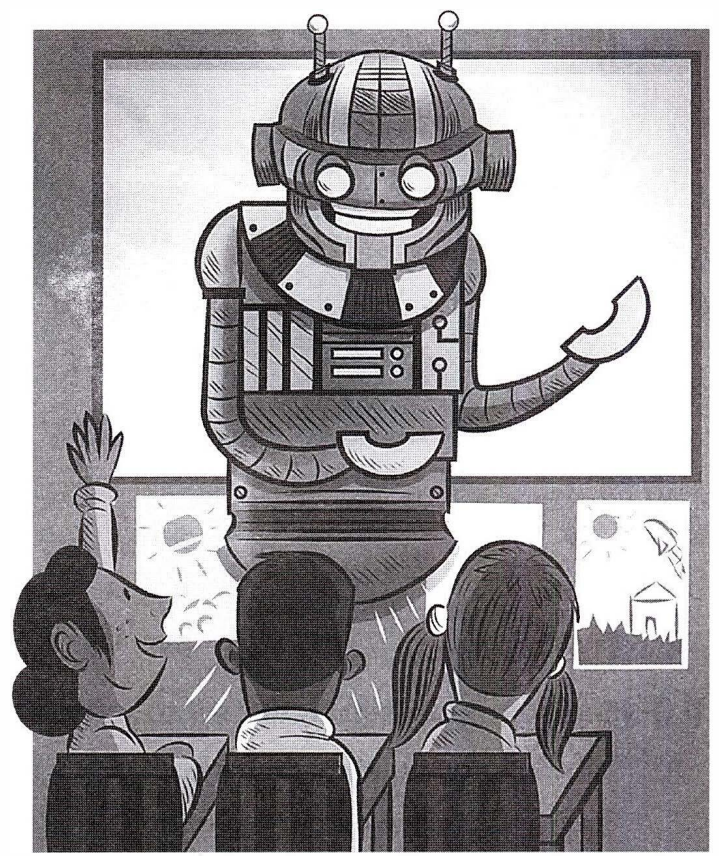

In 2100, I think

---



---



---



---



---



---



---



---



---



---

# Ancient Egypt

1 Complete the words and match them with the pictures.

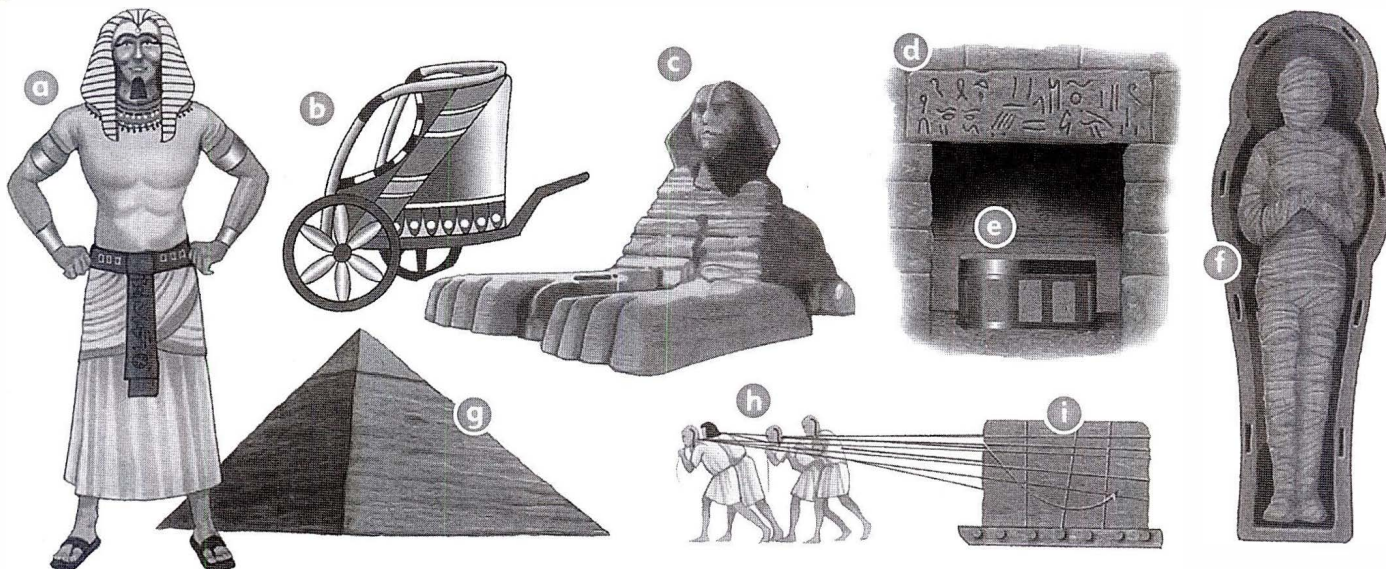

1 r \_ ck       i

2 t \_ mb     

3 ch \_ r \_ \_ t     

4 ph \_ r \_ \_ h     

5 h \_ \_ r \_ glyph \_ cs     

6 pyr \_ m \_ d     

7 m \_ mmy     

8 Sph \_ nx     

9 sl \_ v \_ s     

2 Find four words in Activity 1 to match the definitions.

1 This is a large building in Ancient Egypt. pyramid

2 This is the place where the pharaoh's dead body is buried. \_\_\_\_\_

3 This is a body covered in bandages. You also see this on scary films. \_\_\_\_\_

4 This is a kind of writing used by the Ancient Egyptians. \_\_\_\_\_

3 Complete the dialogue with the words from the box.

blocks Sphinx Pharaoh rock king Egypt slaves chariot

Alex Look! We're in <sup>(1)</sup> Egypt !

Patrick The pyramids ... and the <sup>(2)</sup> \_\_\_\_\_ !

Phoebe I can't believe it! I've always wanted to see the pyramids.

Alex Who's that man on the <sup>(3)</sup> \_\_\_\_\_ ?

Phoebe He's the <sup>(4)</sup> \_\_\_\_\_ . He's a kind of <sup>(5)</sup> \_\_\_\_\_ .

Alex And look at all those <sup>(6)</sup> \_\_\_\_\_ ! That looks like very hard work.

Patrick Yes. I hope they don't find us. I don't want to be pulling giant <sup>(7)</sup> \_\_\_\_\_ of <sup>(8)</sup> \_\_\_\_\_ .



**1 Complete the sentences with the phrases from the box.**

weren't posted    was built    ~~were written~~    wasn't washed

- 1 These plays *were written* by Shakespeare in the seventeenth century.
- 2 This football kit \_\_\_\_\_ after Saturday's match.
- 3 This model pyramid \_\_\_\_\_ by Lucy and Tim for last week's History project.
- 4 Grandma's cards \_\_\_\_\_ this year because we had a party for her.

**2 Complete the dialogue with the past passive of the verbs in brackets.**

**Tourist** These igloos are fantastic. How were they made?

**Guide** Well, the first thing was to find some hard snow. Blocks of hard snow <sup>(1)</sup> *were cut* (cut) and the blocks <sup>(2)</sup> \_\_\_\_\_ (put) on sledges.

**Tourist** And how did the sledges get here?

**Guide** The sledges with the blocks of hard snow <sup>(3)</sup> \_\_\_\_\_ (pull) here by dogs.

**Tourist** I see. And then?

**Guide** The blocks of snow <sup>(4)</sup> \_\_\_\_\_ (make) into a spiral shape and the spiral <sup>(5)</sup> \_\_\_\_\_ (build) higher and higher. The men made that little tunnel as an entrance and then the last few blocks <sup>(6)</sup> \_\_\_\_\_ (move) into the igloo through the entrance and they <sup>(7)</sup> \_\_\_\_\_ (lift) up to form the roof. Finally, the spaces between the blocks <sup>(8)</sup> \_\_\_\_\_ (fill) with snow.

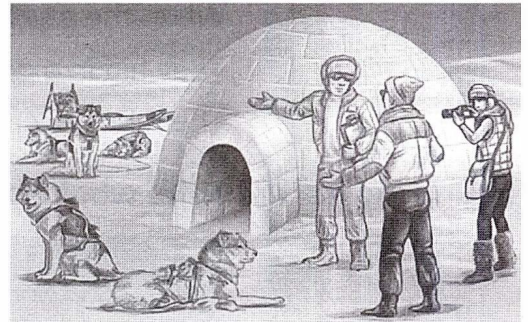

**3 Why wasn't Mum happy when she arrived home? Look at the pictures and write sentences with the past passive of the verbs from the box.**

sweep    feed    tidy    wash

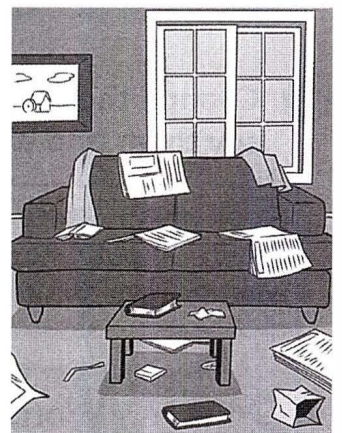
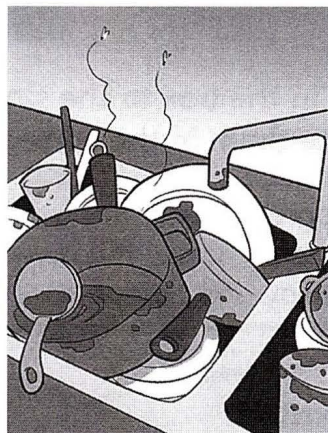

- 1 The dog wasn't fed. \_\_\_\_\_
- 2 \_\_\_\_\_
- 3 \_\_\_\_\_
- 4 \_\_\_\_\_

**1 Think!** Remember the song. Put the sentences in order.

- The boy and the girl closed the lid of the tomb.
- They met a pharaoh and talked to him.
- The boy and the girl ran out of the shop.
- 1 A boy and a girl went to a shop in old Cairo
- The mummy got into the ancient tomb.
- They found an old mummy in the shop.
- The boy and the girl ran to a pyramid.
- When the mummy came to life, they were scared.
- They hid in a dark place behind an ancient tomb.
- The mummy entered the pyramid.



**2 Imagine and write what happened half an hour later.**

□ ■ A I A
□ □ □

Half an hour later, the mummy ...

**3** <sup>CD2</sup><sub>09</sub> Listen and say the words.

decided painted  
jumped arrived

**Phonics tip**

The *-ed* ending sounds like a *t* or a *d*. We only say *id* if the last sound before the *-ed* is a *t* or a *d*.



**4** Change the verbs in the box to the simple past, say them and write them in the correct sound column.

cook wait carry agree need try  
finish shout stop land miss follow  
decide like visit enjoy fix prepare

**Word watch**

We write *enjoyed* and *played*, but in some words we must change the *y* to *i*:  
*hurry* – *hurried*    *try* – *tried*

/t/	/d/	/id/
cooked	carried	waited

**5** <sup>CD2</sup><sub>10</sub> Listen, check and say the words.



1 Rewrite the phrases from the box with *a lot of*, *a few* or *a little*.

half a spoon of blue powder   1 kilo of cheese   3 pirates   23 tomatoes  
 30 students   3 apples   5 jars of green liquid   4 bananas   25 grams of cheese

a little blue powder \_\_\_\_\_

2 Complete the sentences and match them with the pictures.

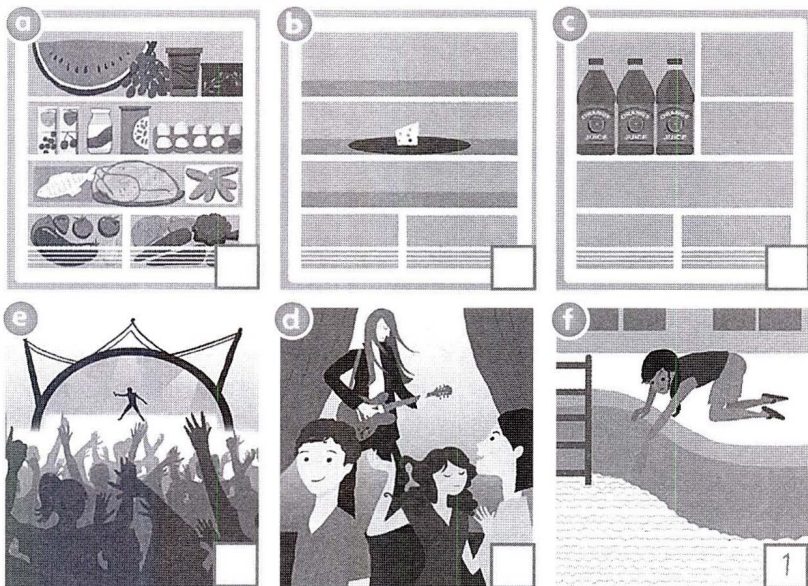

- 1 There was only a little \_\_\_\_\_ water in the pool.
- 2 There was \_\_\_\_\_ food in the fridge.
- 3 There were only \_\_\_\_\_ people at the concert.
- 4 There was \_\_\_\_\_ cheese in the fridge.
- 5 There were \_\_\_\_\_ people at the concert.
- 6 There were \_\_\_\_\_ bottles of juice in the fridge.

3 Look at the pictures and write sentences.



- 1 There are lots of frogs at the pool. \_\_\_\_\_
- 2 \_\_\_\_\_
- 3 \_\_\_\_\_
- 4 \_\_\_\_\_

**1 Remember the story. What does Phoebe think about these things?**

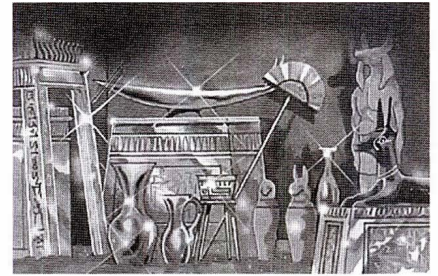
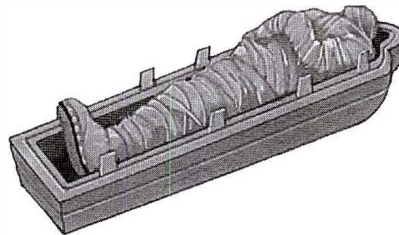

1 She \_\_\_\_\_

2 \_\_\_\_\_

3 \_\_\_\_\_

**2 Who is this pharaoh? Read and complete the summary. Copy the letters that you have written into the spaces below in the same order as the summary.**



The children walk into the pyramid. <sup>(1)</sup> They stop to look at some hieroglyphics, but they don't know what they mean. Patrick goes inside first and the other two follow him. It's very dark and after a few <sup>(2)</sup> minutes, Phoebe screams when something falls on her head. They look around and see <sup>(3)</sup> lots of scorpions. They <sup>(4)</sup> start to <sup>(5)</sup> run down a corridor and they come to a wall. Patrick pushes a button and the floor disappears, so they fall and slide down a long tunnel. They are now in a large, <sup>(6)</sup> dark room. Then Phoebe <sup>(7)</sup> hears something. They all look to where she is pointing and they see a mummy walking towards them. They run towards a light which is in a <sup>(8)</sup> smaller room and they block the door with a rock. When they look around, they see that the room is full of beautiful objects. Phoebe realises that it is a <sup>(9)</sup> tomb and she's happy to stay and look at the treasure, <sup>(10)</sup> but <sup>(11)</sup> the gate appears.

**3 Think! Write t (true), pt (probably true) or f (false).**

1 Patrick is the one who wants to go into the pyramid the most.

 t

2 Alex isn't scared of bugs like scorpions.

3 The button makes the floor disappear.

4 Patrick thinks that it's Alex's fault that they are in the large, dark room.

5 Phoebe is the first to see the mummy.

6 Phoebe wants to get out of the room with the treasure.



1 **Think!** This sign in hieroglyphics tells the children how to escape from the tomb. What do you think it says?

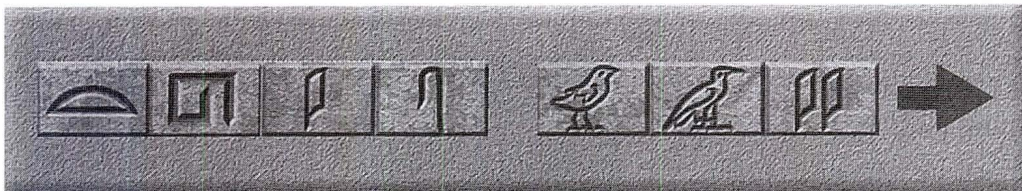

- a Exit
- b Way out
- c This way
- d Follow me

2 Look at the pictures. Complete the holiday advert for Egypt with the words for four of the pictures.

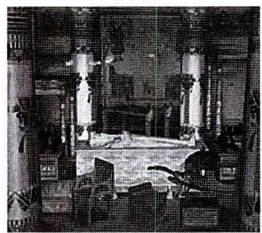

**Fly to Egypt**

Let us take you on a magical trip into the past – to a time when <sup>(1)</sup> pharaoh s ruled the land and rode around in golden <sup>(2)</sup> \_\_\_\_\_ s. Meet the <sup>(3)</sup> \_\_\_\_\_ , half woman, half lion. Visit the Egyptian museum and see the wonderful treasures that were found in the <sup>(4)</sup> \_\_\_\_\_ s of kings and queens in the pyramids.

*Egypt: Bring your imagination to life!*

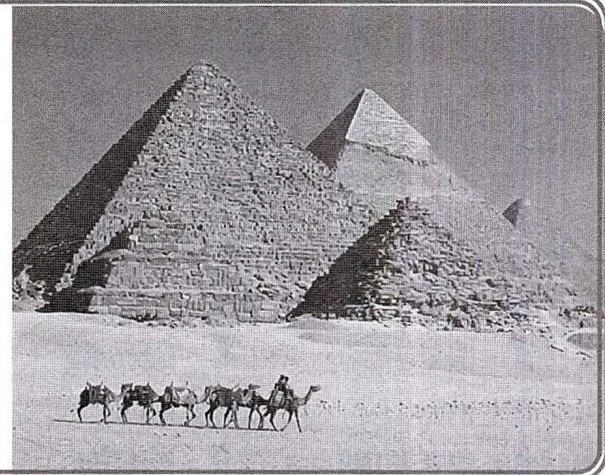

3 Choose a country where you or the Time Travellers have been or where you'd like to visit on holiday. Write a short advert for it.

Fly to \_\_\_\_\_ !

Let us take you \_\_\_\_\_

Meet the \_\_\_\_\_

Visit \_\_\_\_\_



1 Read the article about Tutankhamun. Choose the best word (A, B or C) for each space.

Tutankhamun <sup>(1)</sup> ... probably born in the Ancient Egyptian capital called Akhetaten in the year 1341 BC. When he was nine years old, he <sup>(2)</sup> ... the ruler of Egypt. However, he was only the pharaoh for a <sup>(3)</sup> ... years because he died when he was 18. No-one is sure why he died so young. Some historians think that he was <sup>(4)</sup> ... and others think that he died because of an illness. Not very much <sup>(5)</sup> ...

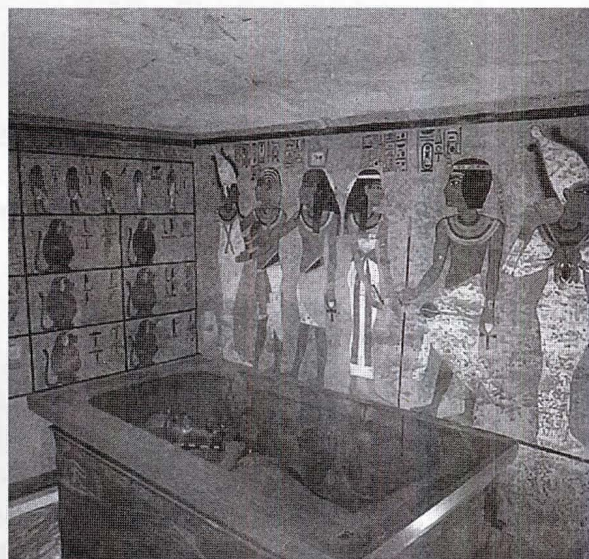

known about him until 1922 when a famous archaeologist called Howard Carter found his tomb in the valley of the kings <sup>(6)</sup> ... Egypt. This discovery was very exciting <sup>(7)</sup> ... the tomb that you can see in this photo was in almost perfect condition and it contained lots of wonderful treasures, including Tutankhamun's beautiful mask. Historians read the hieroglyphics and found out <sup>(8)</sup> ... things about this boy pharaoh. These days, you can find many of the treasures on display in the Egyptian museum in Cairo.

- |   |            |              |             |
|---|------------|--------------|-------------|
| 1 | A is       | <b>B</b> was | C were      |
| 2 | A lived    | B became     | C got       |
| 3 | A little   | B lot of     | C few       |
| 4 | A murdered | B murder     | C murdering |
| 5 | A is       | B was        | C are       |
| 6 | A in       | B on         | C up        |
| 7 | A and      | B but        | C because   |
| 8 | A much     | B how        | C many      |

2 Values Read the text and choose the correct words.

Sign language was invented for people who can't <sup>(1)</sup> **hear** / see. Deaf people can <sup>(2)</sup> **hear** / communicate with sign language. For example, to say *like*, you make a circle with your <sup>(3)</sup> **first** / second finger and your thumb. Signing for the deaf on TV <sup>(4)</sup> **looks funny** / helps people.



**1 Think!** Read the story on Student's Book page 41 again. Complete the table.

Who says ...	... these words ...	... and who to?
(1) <i>one of the girls</i>	'Hurry up, you lazy girl. There's still lots of work to do.'	(2) <i>Rhodopis</i>
(3)	'I bought these for you.'	(4)
(5)	'Ha ha! I'm going to the party.'	(6)
(7)	'Why are they always so mean to me?'	(8)
(9)	'Careful! You've made my shoes wet.'	(10)
(11)	'Hey! Where are you going? That's my shoe!'	(12)
(13)	'I have to find who this shoe belongs to.'	(14)
(15)	'Will you marry me?'	(16)

**2 Read the clues and complete the puzzle.**

- 1 Rhodopis liked to ... by the river.
- 2 The royal palace was in the city of ...
- 3 A ... brings news of the party.
- 4 A big ... carried Rhodopis' shoe away.
- 5 Rhodopis washed her clothes in the ...
- 6 The Pharaoh sat on a ...
- 7 Rhodopis became the queen of ...
- 8 Rhodopis' shoes were a beautiful ... colour.
- 9 The other girls felt ... of Rhodopis.
- 10 Rhodopis was a ... in the old man's house.

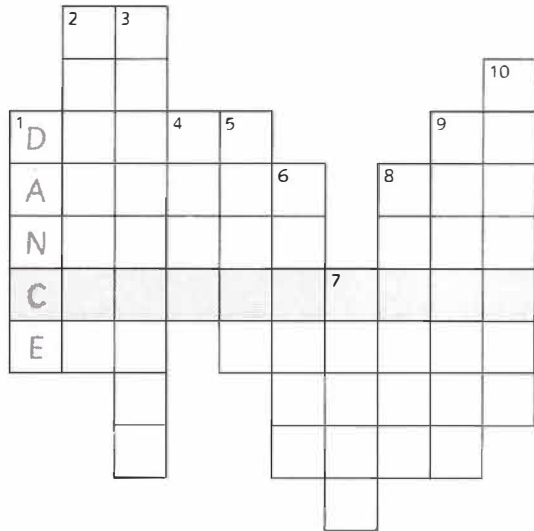

**3 Read and answer the questions.**

The letters in the grey boxes in the puzzle in Activity 2 spell the English name of a girl in a story who is like Rhodopis. Do you know this story or another story like it? What's the girl's name in your language? Why is she like Rhodopis?

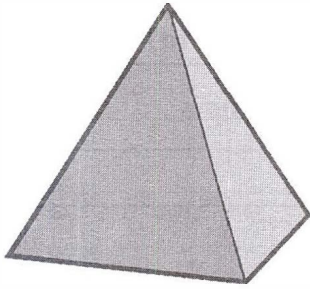

**1** Write the names of the shapes under the pictures.

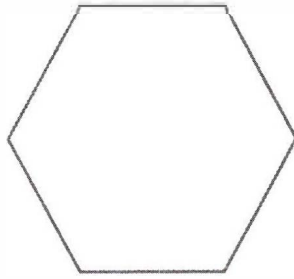

1 square-based pyramid

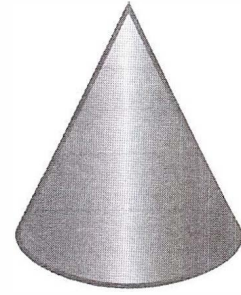

2 \_\_\_\_\_



3 \_\_\_\_\_

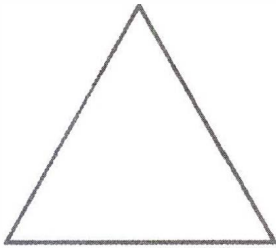

4 \_\_\_\_\_

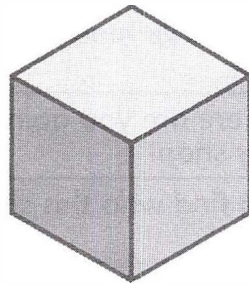

5 \_\_\_\_\_

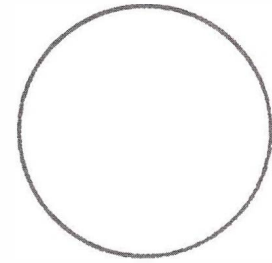

6 \_\_\_\_\_

**2** How many dimensions have each of these shapes got? Write 2 or 3.

- |                    |                                |                        |                      |             |                      |
|--------------------|--------------------------------|------------------------|----------------------|-------------|----------------------|
| 1 cuboid           | <input type="text" value="3"/> | 5 square-based pyramid | <input type="text"/> | 9 square    | <input type="text"/> |
| 2 triangle         | <input type="text"/>           | 6 hexagon              | <input type="text"/> | 10 cone     | <input type="text"/> |
| 3 triangular prism | <input type="text"/>           | 7 cube                 | <input type="text"/> | 11 pentagon | <input type="text"/> |
| 4 rectangle        | <input type="text"/>           | 8 cylinder             | <input type="text"/> | 12 circle   | <input type="text"/> |

**3** Think of objects which are these shapes. Draw them and write the words.

1 a cone  
a traffic \_\_\_\_\_  
cone \_\_\_\_\_

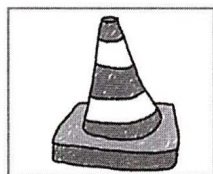

2 a cylinder  
\_\_\_\_\_  
\_\_\_\_\_



3 a square  
\_\_\_\_\_  
\_\_\_\_\_



4 a rectangle  
\_\_\_\_\_  
\_\_\_\_\_



5 a cuboid  
\_\_\_\_\_  
\_\_\_\_\_



6 a circle  
\_\_\_\_\_  
\_\_\_\_\_





**1 Think!** Read the descriptions and answer the questions.

- 1 This shape has got 12 edges and 6 sides. The edges are all the same length.  
 What shape is it? cube  
 How many corners has it got? \_\_\_\_\_
- 2 This shape hasn't got any corners. It's got 3 sides.  
 What shape is it? \_\_\_\_\_  
 How many edges has it got? \_\_\_\_\_
- 3 This shape has got 5 corners and 5 sides. Its edges are usually the same length.  
 What shape is it? \_\_\_\_\_  
 How many dimensions has it got? \_\_\_\_\_

**2 Look at the picture and complete the description.**

My temple is made of 3D shapes. It consists  
 of one \_\_\_\_\_,  
 eight \_\_\_\_\_ and  
 two \_\_\_\_\_.

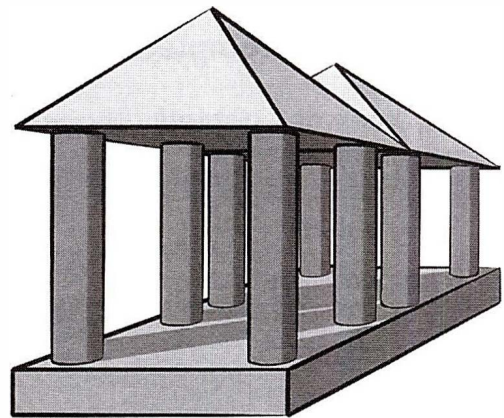

**3 Draw a house using 2D shapes and write a description of it.**

---



---



---



---



---



---



---

- 1** Make three sentences with the phrases in the diamond.  
Use three different phrases in each sentence.

We were \_\_\_\_\_  
 \_\_\_\_\_  
 \_\_\_\_\_  
 \_\_\_\_\_  
 \_\_\_\_\_



- 2** Draw lines and complete the sentences with the phrases from the box.

computer was   got lots   ~~the police~~   were built   time before   wrong on

1	The robbers	of games for	the Ancient Egyptians.
2	The pyramids	a few questions	the train leaves.
3	I've _____	were arrested	_____ the test.
4	She got	little _____	my little brother.
5	We've got a	broken by	my computer.
6	My _____	_____ by	by the police _____.

- 3** Complete the sentences with your own ideas.

- \_\_\_\_\_ were eaten \_\_\_\_\_.
- \_\_\_\_\_ by the teacher.
- I've got lots \_\_\_\_\_.
- There were \_\_\_\_\_ at \_\_\_\_\_.
- He's got a little \_\_\_\_\_.
- \_\_\_\_\_ was found \_\_\_\_\_.





# 4

# Olympic sports

## 1 Complete the sports words.

- |                 |                    |               |
|-----------------|--------------------|---------------|
| 1 boxing        | 5 h _ _ j _ _      | 8 r w _ _     |
| 2 _ y _ ast _ _ | 6 wei _ _ lift _ _ | 9 h _ d _ _   |
| 3 l _ _ j _ _   | 7 f _ _ c _ _      | 10 _ _ ch _ _ |
| 4 _ _ estl _ _  |                    |               |

## 2 Write the words from Activity 1 under the pictures.

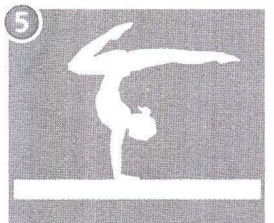
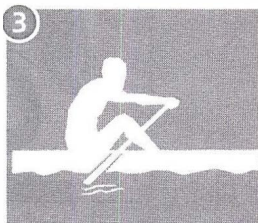
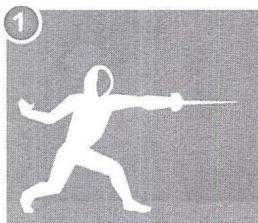

fencing

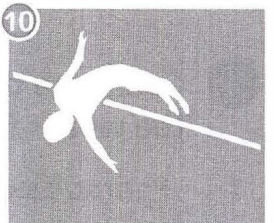
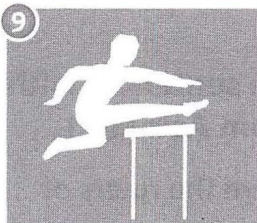
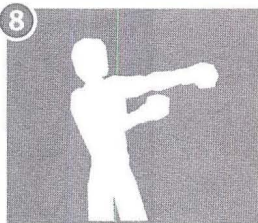
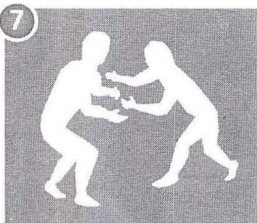
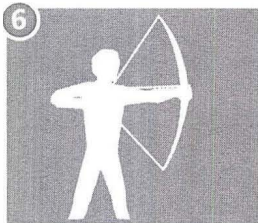

## 3 Year 6 tried different sports for the first time. Which sport from Activity 2 is each student writing about?

⏪ ⏩ 🏠 🔄 🔍

⊞ ⊞ ⊞

### Year 6 ★ 'TRY A NEW SPORT' DAY! ★

1 gymnastics	I fell off, but luckily I didn't hurt myself. (Gemma)
2 _____	It was really difficult and my arrows kept missing the targets. (Taylor)
3 _____	It was great. It was like sword fighting with my brother, but with real swords. (Sam)
4 _____	I could only do 10 kg. My arms aren't very strong. (Rylan)
5 _____	I was terrible at it. I'm OK at long jump and I can jump quite high, but I can't run and jump at the same time! (Jodie)
6 _____	I fell in and got really wet! (Alice)



**Castle Park**



**1 Make sentences.**

- 1 go / watch / fencing / could / I / and / the

---

- 2 you / buy / DVD / Mia / could / a / her / for / birthday

---

- 3 film / about / they / watch / could / the / tonight / Tutankhamun

---

- 4 put / bed / your / we / next / window / could / to / the

---

**2 Complete the dialogues using could.**



A What do you want to do?  
 B We could go snorkelling.

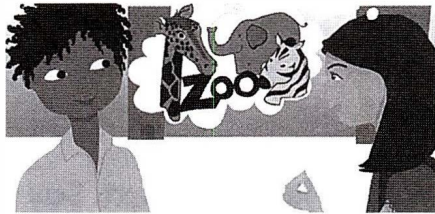

A What shall we do?  
 B We \_\_\_\_\_.

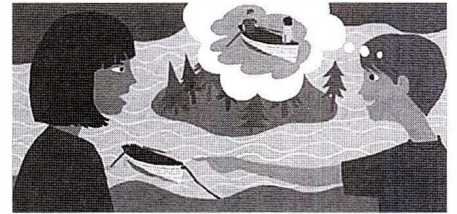

A It's too far to swim.  
 B We \_\_\_\_\_.



A Any ideas?  
 B We \_\_\_\_\_.



A Oh no! My racket!  
 B We \_\_\_\_\_.



A What shall we do?  
 B We \_\_\_\_\_.

**3 Complete the dialogue with the words from the box.**

could could could sounds interested let's starts hurdles shall will

Kylie It's ten past eight now. What <sup>(1)</sup> shall we go and see?  
 Joe Here's the programme. Look, the men's fencing <sup>(2)</sup> \_\_\_\_\_ in forty minutes.  
 We <sup>(3)</sup> \_\_\_\_\_ watch that.  
 Kylie I'm not <sup>(4)</sup> \_\_\_\_\_ in fencing. I think it's boring.  
 Joe OK. We <sup>(5)</sup> \_\_\_\_\_ watch the women's 100 metres <sup>(6)</sup> \_\_\_\_\_.  
 Kylie Not really, look – it started five minutes ago! It <sup>(7)</sup> \_\_\_\_\_ be over by now!  
 Joe You're right. Ah, I know. We <sup>(8)</sup> \_\_\_\_\_ go and see the weightlifting at 8.40.  
 Kylie That <sup>(9)</sup> \_\_\_\_\_ good to me. <sup>(10)</sup> \_\_\_\_\_ go!

**1 Complete the dialogue with the phrases from the box.**

don't think so   why not   that's not such a good idea  
 sorry, but   ~~why would I want to do that~~

**Mia** Let's have a game of badminton.

**Josh** <sup>(1)</sup> Why would I want to do that ?

**Mia** Because it's fun.

**Josh** No, I <sup>(2)</sup> \_\_\_\_\_.

**Mia** Well, let's play football then.

**Josh** <sup>(3)</sup> \_\_\_\_\_ . My mum and dad don't allow it.

**Mia** <sup>(4)</sup> \_\_\_\_\_ ?

**Josh** Because they say that football is bad for the grass.

**Mia** We could play computer games then.

**Josh** <sup>(5)</sup> \_\_\_\_\_ I haven't got a computer.

**Mia** OK, then let's go to my place.



**2 Listen and say the words.**

funny   yellow  
 pyramid   sky

**Phonics tip**

There are four ways of pronouncing the letter y.



A funny yellow pyramid in the sky



**3 Read the text. Say the words with an underlined y and write them in the correct sound column.**

Jenny and Sylvia are at my school. They're young gymnasts who hope to compete at the next Olympics. Yesterday the girls cycled around the city park and then went to the gym. On their way home, the girls were surprised to see a huge yellow pyramid flying slowly in the sky. 'It's a balloon ... on an ice cream van!' said Sylvia. 'Why don't we get a yoghurt ice cream?' said Jenny. 'I've got some money. We've trained really hard and we haven't had a treat yet!'



yes	try	funny	symbol
young	my	Jenny	Sylvia



**4 Listen, check and say the words.**



**1 Complete the sentences with the present continuous of the verbs in brackets.**

- 1 On Monday she *is visiting* her grandma in Cambridge. (visit)
- 2 On Tuesday she \_\_\_\_\_ her friends in the park. (meet)
- 3 On Wednesday she \_\_\_\_\_ shopping with her mum. (go)
- 4 On Thursday she \_\_\_\_\_ tennis with friends. (play)
- 5 On Friday she \_\_\_\_\_ at home. (stay)
- 6 On Saturday she \_\_\_\_\_ to Paris with her parents. (fly)
- 7 On Sunday she \_\_\_\_\_ some sightseeing there. (do)



**2 Write about the week of Heile Dejene, an Ethiopian marathon runner.**

Monday	p.m. fly - New York
Tuesday	p.m. meet trainer
Wednesday	p.m. run 30 km
Thursday	p.m. run 42 km
Friday	a.m. have TV interview p.m. visit museum
Saturday	a.m. see doctor p.m. rest
Sunday	run marathon



On Monday afternoon, Heile's flying to New York.

**3 Write four sentences about your plans for the weekend.**

On Saturday morning ... On Saturday afternoon ... On Sunday morning ... On Sunday afternoon ...

**1 Remember the story. Complete the sentences with the correct names. Match them with the sports in the photos.**

- 1 \_\_\_\_\_ gets a black eye.
- 2 \_\_\_\_\_ hurts a foot.
- 3 \_\_\_\_\_ gets wet.

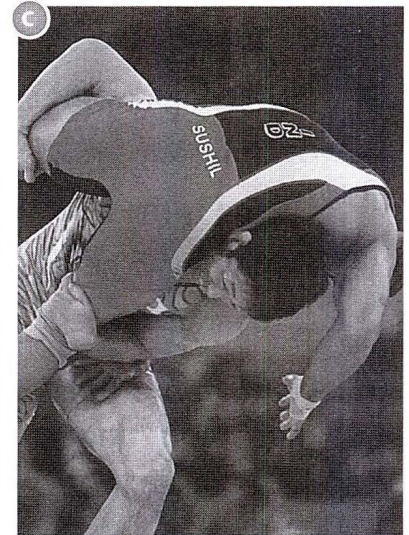
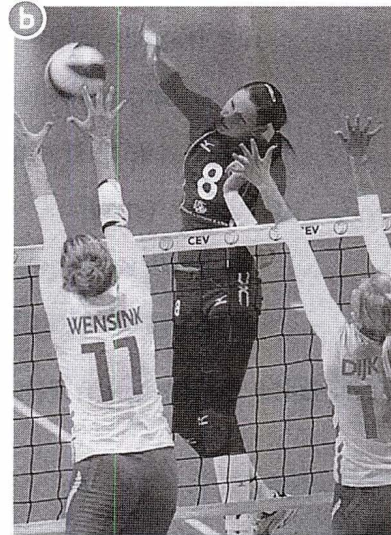
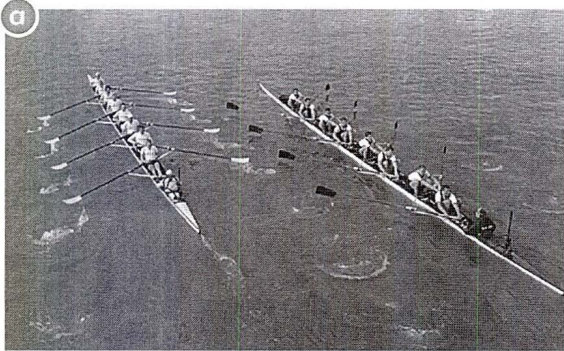

**2 Put the lines in order.**

- atmosphere is amazing and they are really
- Patrick's foot. Finally, the children go to see the
- enjoying the game when Phoebe gets hit
- rowing, which is on a beautiful lake. Again,
- black eye, one has a very sore foot and the other is soaking wet!
- 1 First, the children go to see a volleyball match. The
- that he falls in the water with a big splash. When
- in the face by a ball. Next, they go to a wrestling match. They have great seats
- the gate appears, the three children walk into it: one has a
- the wrestlers throws the other one through the air and he lands on
- the children have seats at the front. Alex gets so excited
- at the front. They watch a really exciting fight, but after the break one of

**3 Answer the questions with *volleyball*, *wrestling* or *rowing*.**

At which event ...

- 1 ... does Patrick think they'll be safe? wrestling
- 2 ... do the crowd count? \_\_\_\_\_
- 3 ... does Phoebe get really excited? \_\_\_\_\_
- 4 ... do they watch 32 people taking part? \_\_\_\_\_
- 5 ... is Patrick sure about who will win? \_\_\_\_\_
- 6 ... do the fans sing? \_\_\_\_\_



**1 Values** What can we learn from the story? Colour the words.

Sport Time Boxing means helps wants  
to bring people dogs up together out .

**2 Think!** Paulo, Cláudia and Marcelo are three Brazilian students who want to see different Olympic sports. Read and write *P* (Paulo), *C* (Cláudia) and *M* (Marcelo) next to the sports in the table.

- Paulo's favourite sports are played in or on water, but he doesn't mind ball games.
- Cláudia doesn't like sports which involve fighting or weapons. She likes athletics and gymnastics.
- Marcelo loves sports that involve fighting and weapons. He doesn't enjoy athletics.

TODAY'S EVENTS			
10 a.m.–12 p.m.	rowing <i>P</i>	wrestling __	gymnastics __
1 p.m.–3 p.m.	long jump __	swimming __	archery __
3 p.m.–5 p.m.	boxing __	high jump __	diving __
5 p.m.–7 p.m.	football __	hurdles __	fencing __

**3** Read the sentences and look at the timetable in Activity 2. Tick (✓) the true sentences or correct the sports.

- Cláudia is watching some athletics from 10 a.m. to 12 p.m. gymnastics
- Marcelo is watching the archery from 1 p.m. to 3 p.m. \_\_\_\_\_
- Paulo is watching the long jump from 1 p.m. to 3 p.m. \_\_\_\_\_
- Cláudia is watching the diving after the long jump. \_\_\_\_\_
- Paulo is watching the football after the diving. \_\_\_\_\_
- Marcelo is watching the boxing before the hurdles. \_\_\_\_\_

**4** Plan your perfect day at the Olympics. Choose any sports that you know in English.

Next Monday at the Olympics

10 a.m.–12 p.m. I'm watching the \_\_\_\_\_ 3 p.m.–5 p.m. \_\_\_\_\_  
1 p.m.–3 p.m. \_\_\_\_\_ 5 p.m.–7 p.m. \_\_\_\_\_

1 CD2  
25

Listen to Maxine talking to Adam about a sports afternoon. What sport did each person do? Write a letter (A–H) next to each person.

People		Sports	
1	Ellie	<input type="checkbox"/>	A fencing
2	Justin	<input type="checkbox"/>	B gymnastics
3	Stacey	<input type="checkbox"/>	C boxing
4	Adam	<input type="checkbox" value="F"/>	D tennis
5	James	<input type="checkbox"/>	E weightlifting
			F rowing
			G archery
			H hurdles

2 CD2  
26

Listen again and answer the questions.

- Who told Maxine that Adam liked sports? *Her brother.*
- When was the sports afternoon?
- Why didn't Maxine go?
- Why couldn't Adam try fencing?
- Why couldn't Justin play tennis?
- What is Adam going to try next week?

3

Complete the five conversations. Choose A, B or C.

- I don't want to go to the wrestling match.  
A Yes, I like it too.      B Why did you watch it?      C Let's not go then.
- Is there time before the game starts?  
A Yes, about half an hour.      B That's alright.      C You're welcome.
- I'm sorry, there aren't any tickets left.  
A It would be great.      B What a pity!      C I hope so.
- What are you going to see tomorrow morning?  
A At 11 o'clock.      B I saw the high jump.      C The long jump.
- See you in half an hour.  
A No, I'm not.      B Don't be late.      C I don't see.



- 1 Work in pairs. Student A: Here is some information about a sports event. Student B: You don't know anything about the event. Ask and answer questions.

**Student A**



**FOOTBALL CUP FINAL**

Wembley Stadium, London  
 Everton - Spurs  
 17<sup>th</sup> May 3.30 p.m.

**Tickets**  
 Adults £38.00  
 Children under 12 free

**Student B**

**FOOTBALL CUP FINAL**

- where?
- who / play?
- time?
- adult ticket £?
- child ticket £?

- 2 Read this email from your English penfriend, Jade.

Write Jade an email. Answer the questions. Write 25–35 words.

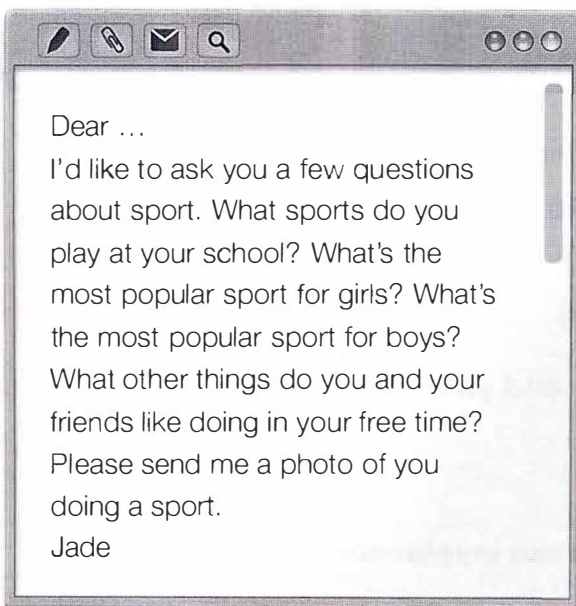

Dear ...

I'd like to ask you a few questions about sport. What sports do you play at your school? What's the most popular sport for girls? What's the most popular sport for boys? What other things do you and your friends like doing in your free time? Please send me a photo of you doing a sport.

Jade

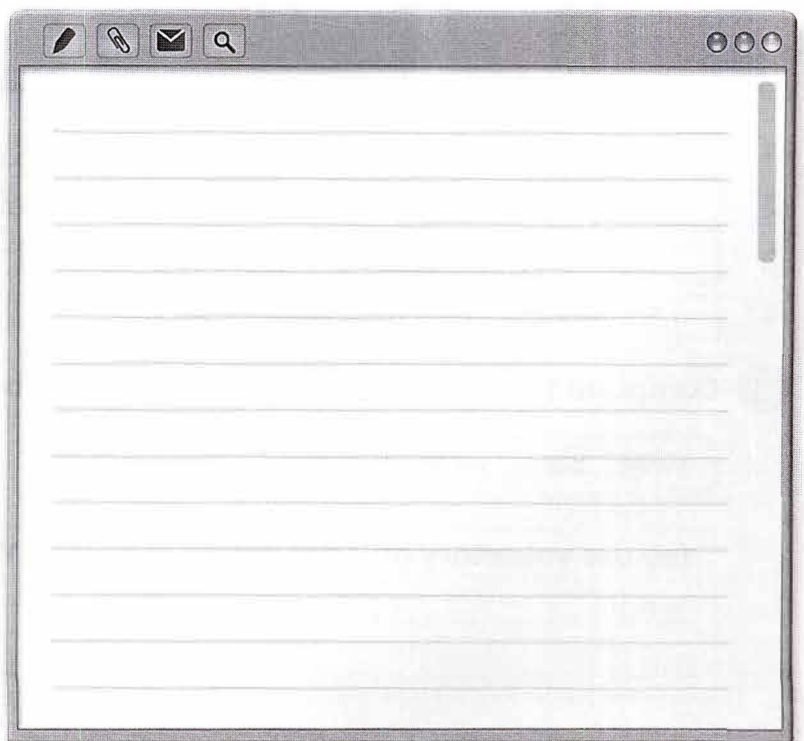



**1 Complete the text with the words from the box.**

skin muscles move body work heart

Muscles control the way that we <sup>(1)</sup> move . Some muscles <sup>(2)</sup> \_\_\_\_\_ and we don't need to think about it, like our <sup>(3)</sup> \_\_\_\_\_ beating. Other muscles are controlled by our thoughts. With their help, we can do different things and move around. There are over 650 muscles in the human <sup>(4)</sup> \_\_\_\_\_. They are under our <sup>(5)</sup> \_\_\_\_\_ and they cover our bones. Muscles often work together to help us move. We don't really have to think about moving each muscle. We just think of running and our <sup>(6)</sup> \_\_\_\_\_ do the rest.

**2 Complete the sentences and match them with the photos.**

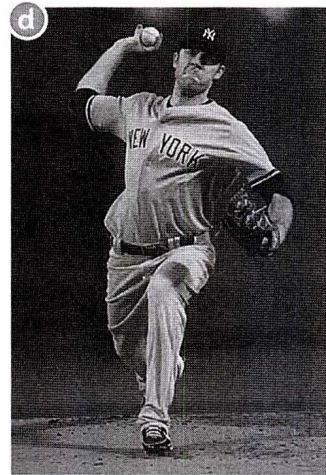
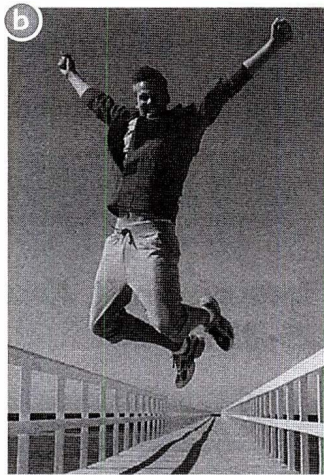
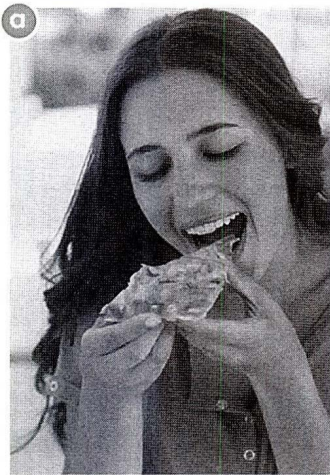

- 1  **b** This person is using their leg muscles to jump high.
- 2  Someone is using their arm and shoulder muscles to t \_\_\_\_\_ a b \_\_\_\_\_ .
- 3  This person's muscles are going to p \_\_\_\_\_ f \_\_\_\_\_ d \_\_\_\_\_ to the stomach.
- 4  Someone is using their leg muscles to r \_\_\_\_\_ a b \_\_\_\_\_ .

**3 Complete the table with the verbs from the box and your answers from Activity 2.**

write blink walk breathe

You use voluntary muscles when you:	You use involuntary muscles when you:
write _____	_____
_____	_____



**1** Read the smart facts on Student's Book page 55 again and answer the questions.

- 1 What language does the word *muscle* come from? *Latin* \_\_\_\_\_
- 2 How many muscles are there in your face? \_\_\_\_\_
- 3 How many muscles in your face do you use when you smile? \_\_\_\_\_
- 4 What are the busiest muscles in the body? \_\_\_\_\_
- 5 How often do you move your busiest muscles every day? \_\_\_\_\_
- 6 What is the biggest muscle in your body? \_\_\_\_\_

**2**  Listen to the dialogue and complete the sentences.



- 1 Jacob feels *very tired* \_\_\_\_\_ .
- 2 His \_\_\_\_\_ .
- 3 Jacob didn't do any \_\_\_\_\_ .
- 4 In his free time yesterday, he \_\_\_\_\_ .
- 5 He ate \_\_\_\_\_ .
- 6 He loves \_\_\_\_\_ .

**3** Write an email to Jacob. Tell him how he could have a healthier life.

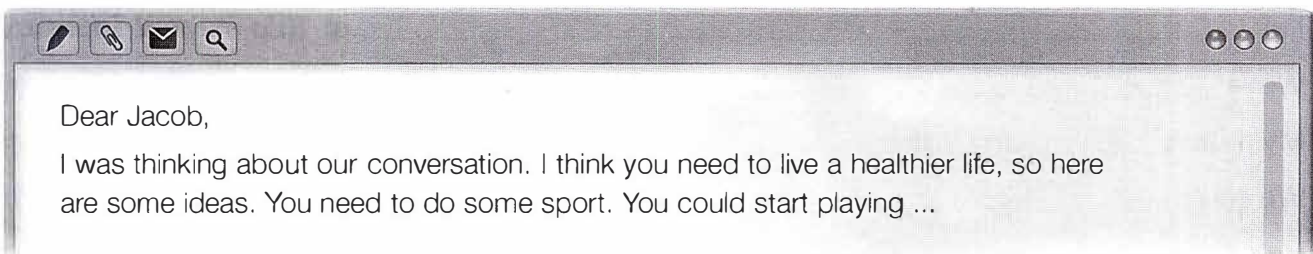

Dear Jacob,

I was thinking about our conversation. I think you need to live a healthier life, so here are some ideas. You need to do some sport. You could start playing ...

**1 Choose six words or phrases to complete the sentences.**

<b>she could</b>	1 We <i>could go</i> _____ and see a film later.	<b>could we</b>
<b>they're flying</b>	2 I'm _____ aunt this weekend.	<b>are flying</b>
<b>am visiting</b>	3 _____ buy her dad a book for his birthday.	<b>could</b>
<b>could go</b>	4 _____ rowing on Saturday.	<b>visiting my</b>
<b>we're going</b>	5 He's _____ piano lesson tomorrow.	<b>having a</b>
	6 _____ to Greece in the morning.	

**2 There is a word missing from these sentences. Write each sentence with a word from the box in the correct place.**

do are is ~~could~~ a seeing

1 We have pizza for dinner tonight.

*We could have pizza for dinner tonight.*

2 We could our homework together.

3 I'm Anne this afternoon.

4 Sam and Zak playing tennis at 3 p.m.

5 They're having party on Sunday.

6 Freya sleeping at her friend's house tonight.

**3 Complete the sentences with your own ideas.**

1 We could \_\_\_\_\_ this evening.

2 I'm \_\_\_\_\_ at 10 a.m. next Saturday.

3 We're \_\_\_\_\_ tonight.

4 My mum's \_\_\_\_\_ evening.

5 We could \_\_\_\_\_ for lunch.

6 He's \_\_\_\_\_ tomorrow morning.





## 1 Complete the shops and match them with the pictures.

a

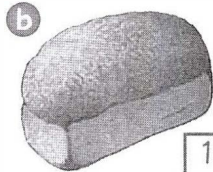
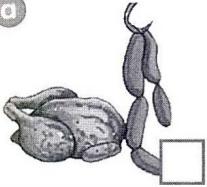

c

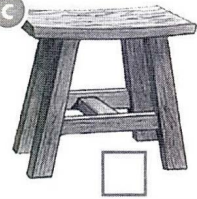

- 1 baker's
- 2 ro... 's
- 3 ...ch... 's
- 4 a b... 's
- 5 ...ew... e 's
- 6 ...p... t... 's
- 7 h m... 's
- 8 ...ai o 's

e



g

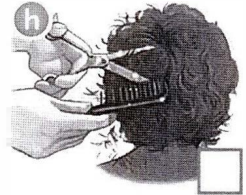

## 2 Which of the shops from Activity 1 are these people in?

- 1 'Would you like some sausages too?'  
butcher's
- 2 'Have you got any toothpaste?'  
\_\_\_\_\_
- 3 'How much is it for a hair wash?'  
\_\_\_\_\_
- 4 'I want a special necklace for my wife's birthday.'  
\_\_\_\_\_
- 5 'These trousers are too long.'  
\_\_\_\_\_
- 6 'Can you make me some chairs too?'  
\_\_\_\_\_
- 7 'I'd like some apples, please.'  
\_\_\_\_\_
- 8 'How much is that cake?'  
\_\_\_\_\_

## 3 Complete the email with the words from the box.

interesting wood people built  
buildings finished Thames



Hi Carlos

You asked me for some information for your project. Well, yesterday I <sup>(1)</sup> finished \_\_\_\_\_ reading a book about the fire of London. It was quite <sup>(2)</sup> \_\_\_\_\_. At that time, only about 200,000 <sup>(3)</sup> \_\_\_\_\_ lived in London. Today there are 8 million. Anyway, in September 1666, a fire started north of the River <sup>(4)</sup> \_\_\_\_\_ and the city burned for four days. Almost 80% of the <sup>(5)</sup> \_\_\_\_\_ were destroyed. After the fire, London was <sup>(6)</sup> \_\_\_\_\_ again with wider streets and houses made of brick, not <sup>(7)</sup> \_\_\_\_\_.

Write and tell me if you need more. We don't study Spanish history – only Spanish words!

Dylan



**1 Match the past participles from the box with the correct verbs.**

caught seen sung eaten been found drunk won slept broken ridden driven

- |              |           |           |            |
|--------------|-----------|-----------|------------|
| 1 see – seen | 4 sing –  | 7 be –    | 10 drink – |
| 2 win –      | 5 eat –   | 8 find –  | 11 break – |
| 3 ride –     | 6 drive – | 9 sleep – | 12 catch – |

**2 Complete the dialogues. Use *ever* and *never*.**

- 1 A Have you ever baked bread? (bake)  
 B No, I've never baked bread, but I 've baked cakes with my mum. (bake)
- 2 A \_\_\_\_\_ a monster? (see)  
 B No, \_\_\_\_\_ a monster, but I \_\_\_\_\_ people in costumes! (see)
- 3 A \_\_\_\_\_ crocodile eggs? (eat)  
 B No, \_\_\_\_\_ crocodile eggs, but I \_\_\_\_\_ lots of hens' eggs. (eat)
- 4 A \_\_\_\_\_ a prize? (win)  
 B No, \_\_\_\_\_ a prize, but I \_\_\_\_\_ a few races at school.
- 5 A \_\_\_\_\_ a camel? (ride)  
 B No, \_\_\_\_\_ a camel, but I \_\_\_\_\_ an elephant. (ride)
- 6 A \_\_\_\_\_ your leg? (break)  
 B No, \_\_\_\_\_ my leg, but I \_\_\_\_\_ my arm. (break)

**3 Look at the pictures. Write questions and answers.**

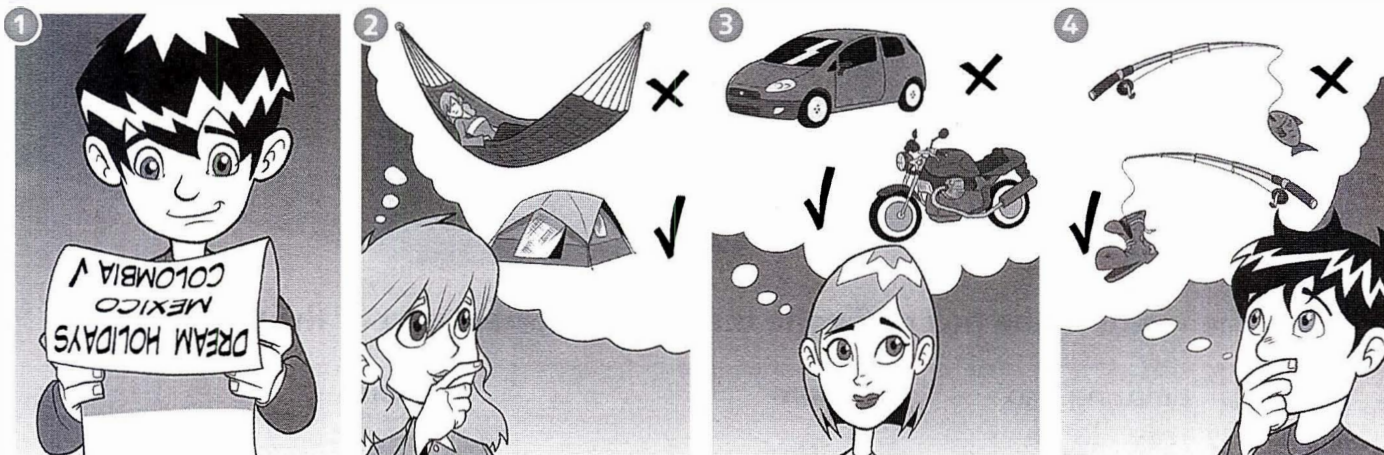

- 1 Has he ever been to Mexico? \_\_\_\_\_ No, he hasn't, but he's been to Colombia.
- 2 \_\_\_\_\_
- 3 \_\_\_\_\_
- 4 \_\_\_\_\_

**1 Match the rhyming words. Write two more words for each rhyme.**

- |   |        |        |            |
|---|--------|--------|------------|
| 1 | there  | meet   | _____      |
| 2 | zoo    | home   | _____      |
| 3 | own    | square | _____ bear |
| 4 | street | do     | _____      |

**2 Remember the song. Write questions asking about each city. Then answer them.**

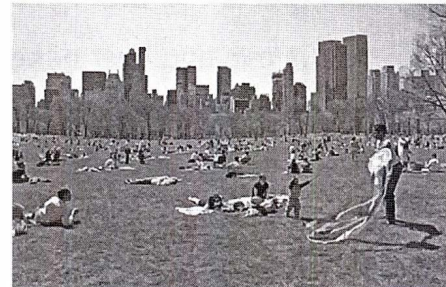

- |   |                    |   |         |   |         |
|---|--------------------|---|---------|---|---------|
| 1 | Have you ever been | 2 | _____   | 3 | _____   |
|   | _____ ?            |   | _____ ? |   | _____ ? |

**3** <sup>CD 3</sup><sub>08</sub> Listen and say the sentence.

Snakes hiss and bees buzz.

**Phonics tip**

Make a sss sound like a snake and a zzz sound like a bee. Can you hear the difference?

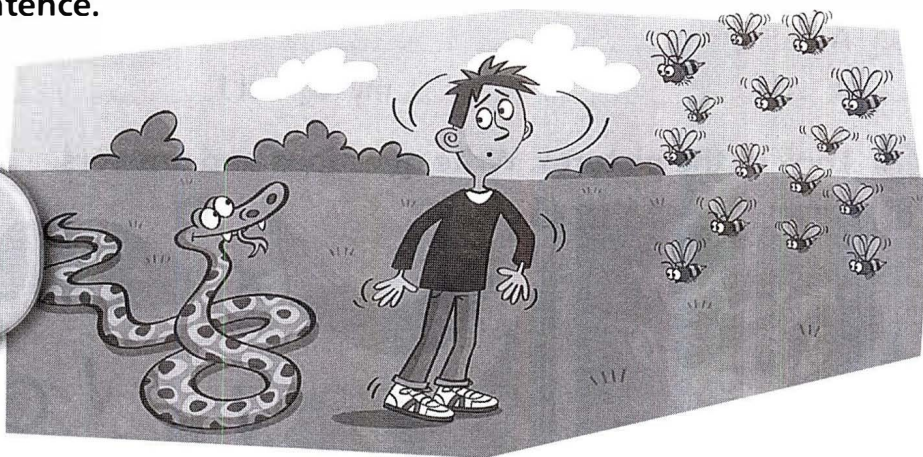

**4 Say the words in the box and write them in the correct part of the table.**

this is amazing so  
animals city listen  
realise sharks paints  
present eyes concert  
noise escapes bridges

Sam	Zara
this	is
_____	_____
_____	_____
_____	_____

**5** <sup>CD 3</sup><sub>09</sub> Listen, check and say the words.



**1 Match the questions with the answers.**

- |   |   |   |                                     |  |
|---|---|---|-------------------------------------|--|
| 1 | Have you ever tried coconut milk?               | a | <input type="checkbox"/>            | Yes, they have. They were in London in March.                                |
| 2 | Have your parents ever been to Britain?         | b | <input type="checkbox"/>            | Yes, I have. I saw <i>Romeo and Juliet</i> with my grandparents last summer. |
| 3 | Has your brother ever read a Harry Potter book? | c | <input type="checkbox"/>            | Yes, you have. We played it on the beach last year. Remember?                |
| 4 | Have you ever seen a Shakespeare play?          | d | <input checked="" type="checkbox"/> | Yes, I have. I tried it last year in Brazil.                                 |
| 5 | Have I ever played badminton?                   | e | <input type="checkbox"/>            | No, I haven't, but I found a key in the street last year.                    |
| 6 | Have you ever found any money?                  | f | <input type="checkbox"/>            | No, he hasn't, but he watched all the films on DVD last month.               |

**2 Put the dialogue in order.**

- A Ugh! Poor frog! I've never seen a snake eating a frog.
- A A photo? Why?
- A Really? Were you scared?
- 1 A Have you ever seen a snake in your garden, Max?
- A No, I haven't ... but my brother told me about the film *Snakes on a plane*.
- B No, I wasn't. I took a photo. It was just there, by the pond.
- B Have you ever seen a snake at all?
- B Because the snake was eating a frog.
- B Yes, I have. Actually, it was two days ago.



**3 Look at the pictures and write dialogues.**



- |   |   |   |
|---|---|---|
| 1 | <b>A</b> Have you ever been skiing? _____ | <b>B</b> Yes, I have. I went last winter. _____ |
| 2 | <b>A</b> _____                            | <b>B</b> _____                                  |
| 3 | <b>A</b> _____                            | <b>B</b> _____                                  |
| 4 | <b>A</b> _____                            | <b>B</b> _____                                  |

1 Remember the story. Circle the form of transport which is not in the story.

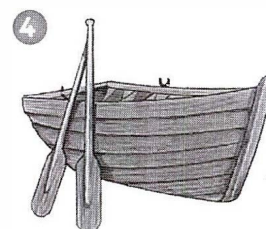
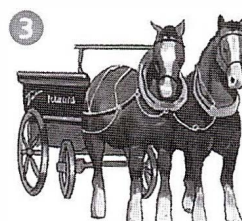
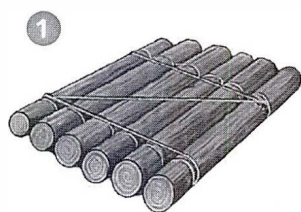

2 Read the summary. Where should this information go in the summary?

- a Patrick rescues the boy
- b to leave the city
- c Mr Fisher is worried
- d from a raft onto a boat
- e but there isn't enough room for everyone
- f ~~where his wife and children are waiting~~
- g to put a big chest onto the cart
- h who are trying to escape across the river

The children go with Mr Fisher and he tells them about the fire. He invites the children to escape with his family to the countryside and he takes them to his house <sup>(1)</sup> . On the way there, they see lots of people <sup>(2)</sup>  in boats. They see a man step <sup>(3)</sup>  and a child falls into the water. <sup>(4)</sup>  and the woman on the boat gives him a bracelet to say thank you.

They arrive at Mr Fisher's house and help him <sup>(5)</sup> . Then they all get onto it <sup>(6)</sup> , but just then a woman arrives with a group of children. She wants to go with them, <sup>(7)</sup> . The friends jump down from the cart and give their spaces to the woman and the children. <sup>(8)</sup> , but they tell him that they know another way to escape and they leave through the gate.

3 Complete the puzzle. Look at the grey boxes. Find the name of the king of England at the time of the Great Fire.

- 1 Some people took these animals onto the boats with them.
- 2 The people were trying to cross this river.
- 3 This is flat, made of wood and you can travel on water with it.
- 4 Mr Fisher has two of these animals.
- 5 A woman gives this to Patrick.
- 6 This is a word for chairs, armchairs, sofas and tables.
- 7 This is a big box.

The king at the time of the Great Fire of London was King \_\_\_\_\_ II.

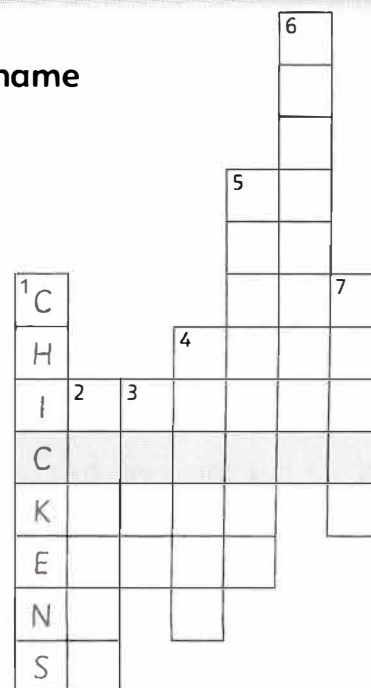



**1 Think!** Read about the man trying to escape from the fire. Can you help him?

A man is trying to escape from the fire of London by boat across the River Thames. He wants to take his pet fox, his chicken and a bag of grain with him. His boat is small, so he can only take one thing with him each time. If he leaves the chicken and the grain together, the chicken will eat the grain. If he leaves the fox and the chicken together, the fox will eat the chicken. How can he get all three things safely to the other side?



He should \_\_\_\_\_

**2 Look at the pictures. How could the children think of others? Complete the sentences.**

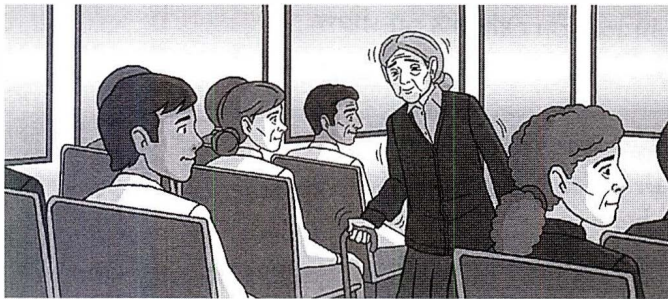

1 He could *give her his seat* \_\_\_\_\_

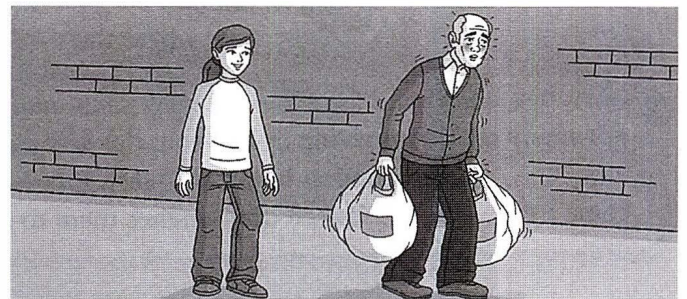

2 She could \_\_\_\_\_



3 He could \_\_\_\_\_

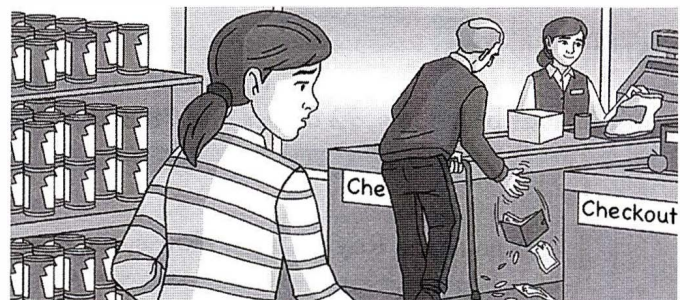

4 She could \_\_\_\_\_

**3 Values** Tick (✓) the best thing to say for each picture in Activity 2.

- 1 a Sit here.
- 2 a Those bags look heavy.
- 3 a Shall I reach that for you?
- 4 a You've dropped some money.

- b Would you like this seat?
- b Can I help you with those?
- b You're too short.
- b I'll get that for you.

1 Look at the photos. Complete the texts with the names of the places.

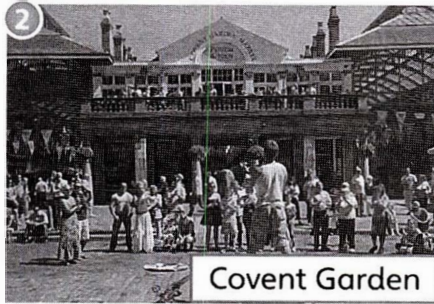

a About 100 years ago, <sup>(1)</sup> Covent Garden was a busy fruit and vegetable market. Over the years, it has changed a lot and now it is a very popular tourist destination. There are many small independent shops there and you can find lots of interesting things to buy.

b A trip to London isn't complete without a visit to the <sup>(2)</sup> \_\_\_\_\_, where there are eight million exhibits on show.

c For many tourists arriving in London, the first place they want to see is <sup>(3)</sup> \_\_\_\_\_, the London home of Queen Elizabeth II. When heads of states from other countries come to the UK, the Queen often invites them to stay here.

d The <sup>(4)</sup> \_\_\_\_\_ is one of the biggest in the world and you could spend weeks there to see all of it. Of course, it has many objects from British history over the years, but it's not just things from Britain.

e <sup>(5)</sup> \_\_\_\_\_ is huge. It has 19 big halls, 52 bedrooms, 188 staff bedrooms, 92 offices and 78 bathrooms.

f <sup>(6)</sup> \_\_\_\_\_ is now famous for entertainment. It is the home of the Royal Opera House, the most famous place to see opera in the UK.

g You always know when the Queen is at home in <sup>(7)</sup> \_\_\_\_\_ because the flag is flown.

h However, if you don't like that kind of music or if it's too expensive, you can just sit and watch one of the many street performers in <sup>(8)</sup> \_\_\_\_\_ for free.

i You can find interesting exhibits in the <sup>(9)</sup> \_\_\_\_\_ from all over the world. You have to pay for some exhibitions, but there are plenty of things to see for free.



1 CD3  
13

You will hear a woman asking for information about a train.  
Listen and complete the notes.

Train

To: (1) London

Day of journey: (2) \_\_\_\_\_

Train leaves at: (3) \_\_\_\_\_

Return ticket costs: (4) \_\_\_\_\_

Food on train: (5) Drinks and \_\_\_\_\_

Website address: (6) \_\_\_\_\_

- 2 Alison wants to go to London on Thursday. She needs to get there by 10 a.m. She phones for some information. Write a dialogue.

Alison Hello. I'd like some information about trains to London, please.

- 3 Read the sentences about a trip to London. Choose the best word (A, B or C) for each space.

- Lucy and Julia ... on a school trip to London last week.  
 (A) went                      B visited                      C came
- The first ... that they visited was Buckingham Palace.  
 A museum                      B place                      C castle
- They ... lots of photos with their phones.  
 A made                      B did                      C took
- The teacher then took the children on a guided ... of the palace.  
 A visit                      B tour                      C walk
- Lucy and Julia got lost and walked ... the wrong corridor.  
 A in                      B over                      C down
- They opened a door and ... the Queen!  
 A spoke                      B talk                      C met

1 Look at the paintings and write *i* (impressionism) or *r* (realism).

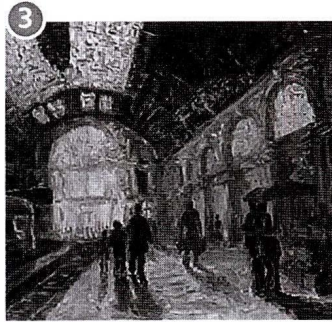
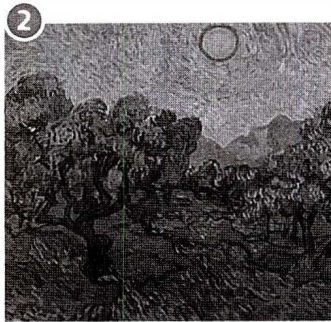
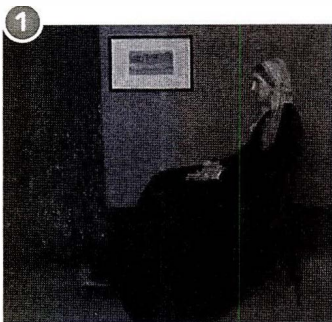

Whistler's Mother  *r* Olive Trees with Yellow Sky and Sun  Keleti  The Gleaners

2 Write the phrases from the box in the correct frame.

~~look like they were painted quickly~~ show things as they really are  
 show a lot of detail often look more like photographs  
 don't show a lot of detail give a 'feeling' of the subject

**Realistic paintings**

---



---



---

**Impressionist paintings**

*look like they were painted quickly*

---



---



---

3 Read the text on Student's Book page 66 again. Complete the table.

<b>A quick guide to the Impressionists</b>	
Famous artists include:	(1) Renoir, _____ _____
Liked to paint:	(2) _____ _____
Didn't paint:	(3) _____
The way they painted:	(4) _____
How to look at their paintings:	(5) _____ _____



- 1 Look at the painting. What do you think? Circle the adjective which describes it best.

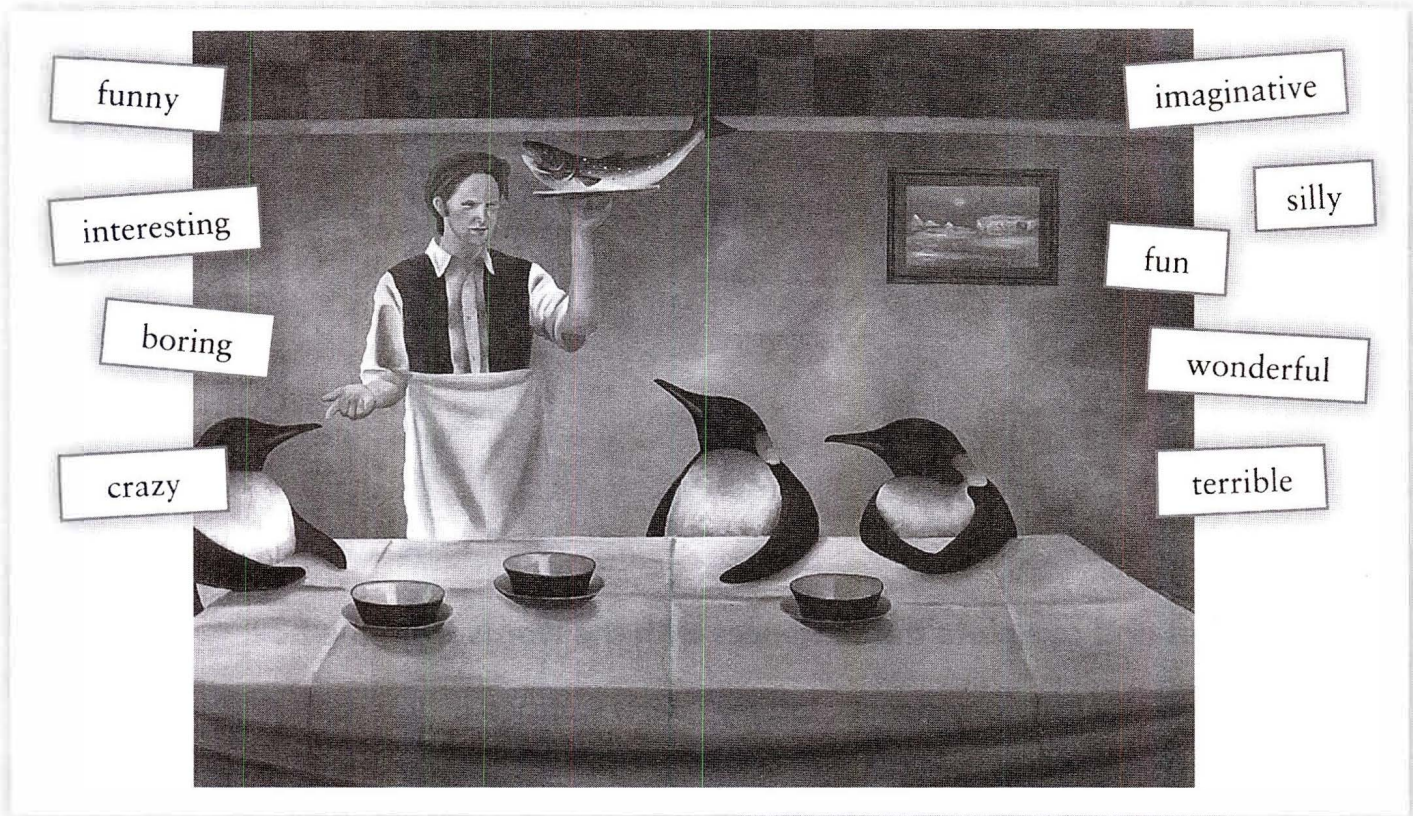

- 2 Read Beth's text. Underline the information in different colours.

- What does the painting show? (red)
- What is Beth's opinion of it? (blue)
- What does she explain about the style of art? (green)

My favourite painting is called *Waiter and penguins* by an English artist called Michael Forbes. The painting shows three penguins in a restaurant. They are sitting around a table, where there are bowls and plates, and the penguins have their flippers on the table, like human arms. A waiter is bringing them a large fish on a plate. I like it because it's very imaginative. It's painted in a surreal style. Surreal artists paint realistically, but they paint crazy scenes which look like they have come from a dream.

Beth Mead

- 3 Write a short text about your favourite painting from Student's Book or Workbook page 66 or choose another painting that you prefer.

- 1 Make three sentences with the phrases in the diamond. Use three different phrases in each sentence.

Have you \_\_\_\_\_  
 \_\_\_\_\_  
 \_\_\_\_\_  
 \_\_\_\_\_  
 \_\_\_\_\_

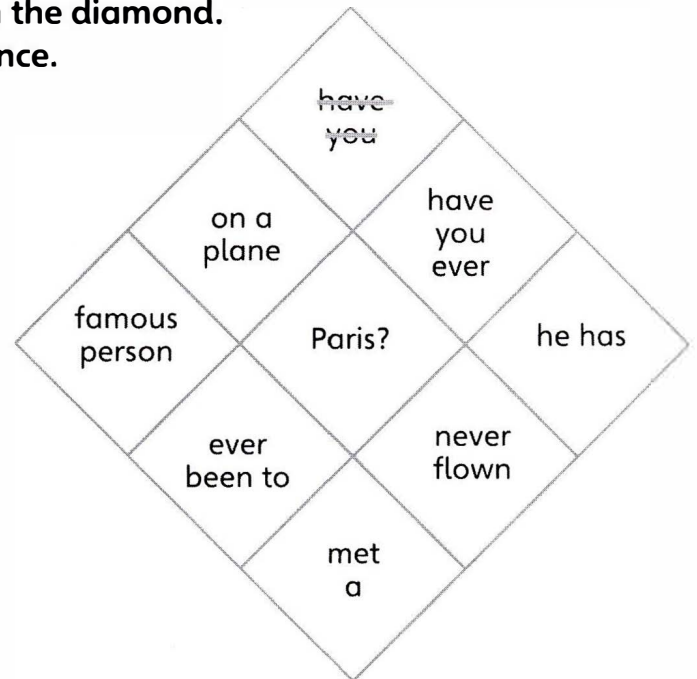

- 2 Draw lines and complete the sentences with the words from the box.

ever been TV last ~~any money~~ lost my never watched a last year

1 Have you ever _____	football match	in the street?
2 Has she _____	the film on _____	her mum _____.
3 I have _____	_____ to _____	_____ night.
4 I didn't like _____	pen at _____	on TV!
5 She went _____	found <del>any money</del> _____	school yesterday.
6 I _____	to Spain with _____	a foreign country?

- 3 Complete the sentences with your own ideas.

- Have you ever \_\_\_\_\_ ?
- I've never \_\_\_\_\_ .
- I \_\_\_\_\_ last night.
- Have \_\_\_\_\_ Japanese food?
- We \_\_\_\_\_ in 2009.
- Has she ever \_\_\_\_\_ ?





# Crazy inventions

1 Find eleven words in the wordsquare.

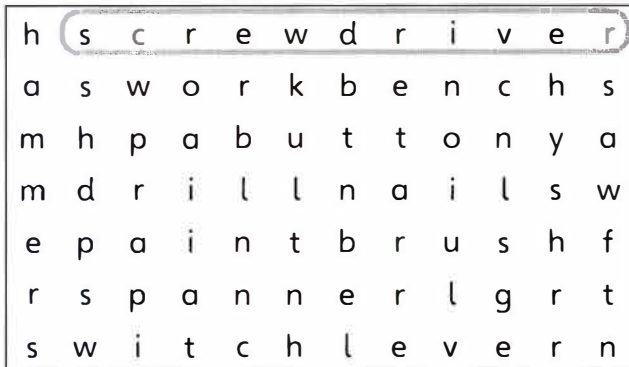

Which word from Student's Book page 70 is missing?

2 Match the words from Activity 1 with the pictures.

1 workbench

- 2 \_\_\_\_\_  
3 \_\_\_\_\_  
4 \_\_\_\_\_  
5 \_\_\_\_\_  
6 \_\_\_\_\_  
7 \_\_\_\_\_  
8 \_\_\_\_\_  
9 \_\_\_\_\_  
10 \_\_\_\_\_  
11 \_\_\_\_\_  
12 \_\_\_\_\_

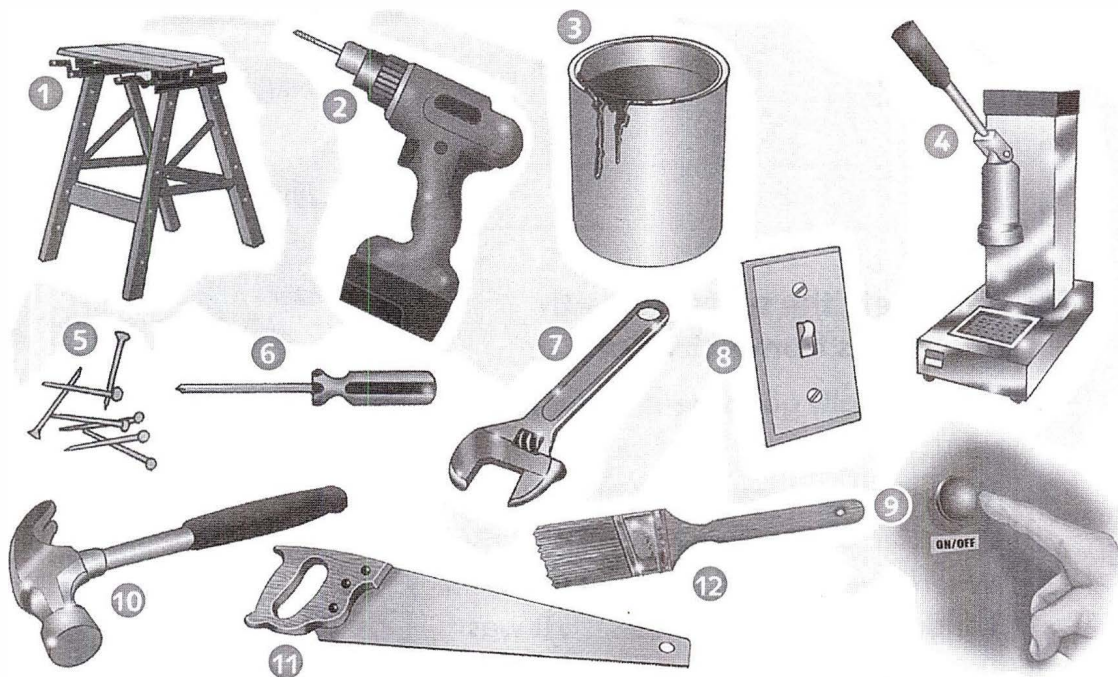

3 Choose words from Activity 2 to complete the dialogue.

**Phoebe** Well, he certainly looks like a professor. Let's go over to his <sup>(1)</sup> workbench and talk to him.

**Patrick** Excuse me.

**Professor** Just a minute. Just a minute. I've nearly finished. Pass me that <sup>(2)</sup> \_\_\_\_\_, please, and a few <sup>(3)</sup> \_\_\_\_\_s.

**Alex** Here you are.

**Professor** Thank you. ... Now one quick turn of the <sup>(4)</sup> \_\_\_\_\_ and that's it!



**1 Choose the correct words.**

- 1 Sorry, I can't help you with your homework. I haven't got **too many** / **enough** time.
- 2 You can't have a high mark because there are **too many** / **enough** mistakes in your test.
- 3 I'm so busy. I've got **too many** / **enough** things to do.
- 4 We can have some food first. There's **too many** / **enough** time before the train leaves.
- 5 I don't like driving here. There are **too many** / **enough** holes in the road.
- 6 I can't buy the DVD today because I haven't got **too many** / **enough** money.

**2 Complete the dialogue with *too many* and *enough*.**

Paul Have we got <sup>(1)</sup> enough \_\_\_\_\_ food for the party?  
 Lily Yes, I'm sure there's <sup>(2)</sup> \_\_\_\_\_ food. Last time we made <sup>(3)</sup> \_\_\_\_\_ sandwiches and we were eating them all weekend!  
 Eva But there isn't <sup>(4)</sup> \_\_\_\_\_ to drink.  
 Paul OK, I'll get some more bottles of orange juice.  
 Eva There are <sup>(5)</sup> \_\_\_\_\_ armchairs in the room. We need more space to dance.  
 Lily How many CDs have we got?  
 Paul Erm ... 43, I think.  
 Lily That's <sup>(6)</sup> \_\_\_\_\_ ! We can't play them all.  
 Paul But last time we didn't have <sup>(7)</sup> \_\_\_\_\_ CDs. Anyway, we don't need to play them all.  
 Eva Right. You can never have <sup>(8)</sup> \_\_\_\_\_ CDs.



**3 Write sentences with *too many* and *enough*.**

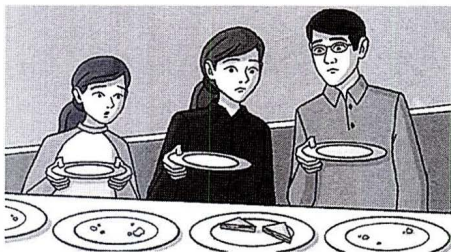

1 There isn't enough food.

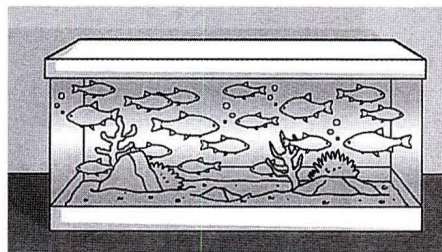

2 \_\_\_\_\_

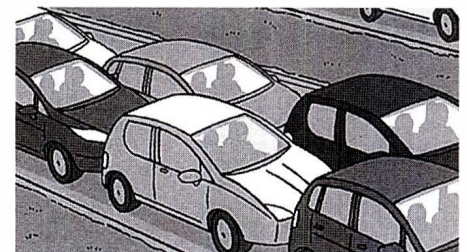

3 \_\_\_\_\_

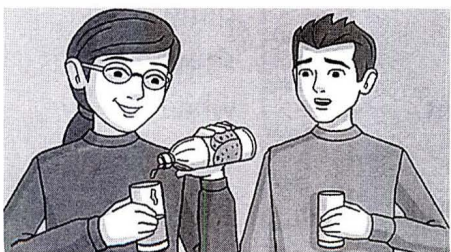

4 \_\_\_\_\_

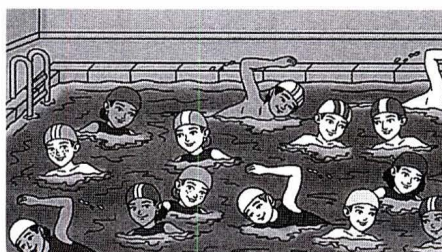

5 \_\_\_\_\_



6 \_\_\_\_\_

**1** Read the dialogue on Student's Book page 72 again. Complete the summary.

Josh is making a model <sup>(1)</sup> plane . It's a biplane, so it's got <sup>(2)</sup> \_\_\_\_\_ wings, but it hasn't got any <sup>(3)</sup> \_\_\_\_\_. He's going to paint it <sup>(4)</sup> \_\_\_\_\_ with a bit of <sup>(5)</sup> \_\_\_\_\_.

**2** Complete the dialogue with the phrases from the box.

at the back   enough   why   reason for that   what about   finished it yet

**Olivia** Hey, what are you doing?

**Mia** I'm making an owl for my Science project, but I haven't <sup>(1)</sup> *finished it yet*.

**Olivia** Er, Mia, an owl hasn't got eyes <sup>(2)</sup> \_\_\_\_\_ of its head.

**Mia** These eyes aren't real eyes. They're feathers that *look* like eyes so that other animals will think that the owl is looking at them.

**Olivia** Oh, I see. But <sup>(3)</sup> \_\_\_\_\_ legs? I can't see any legs.

**Mia** The <sup>(4)</sup> \_\_\_\_\_ is because the legs are hidden by feathers.

**Olivia** Oh. And what colour is your owl going to be?

**Mia** Grey with black and brown.

**Olivia** But you haven't got <sup>(5)</sup> \_\_\_\_\_ brown paint there.

**Mia** It's camouflaged. That's <sup>(6)</sup> \_\_\_\_\_ I've only got a bit of brown. It's mostly grey.

**3**  Listen and say the words.

light   enough   through

**Phonics tip**

There are different ways of pronouncing the letters *gh*.

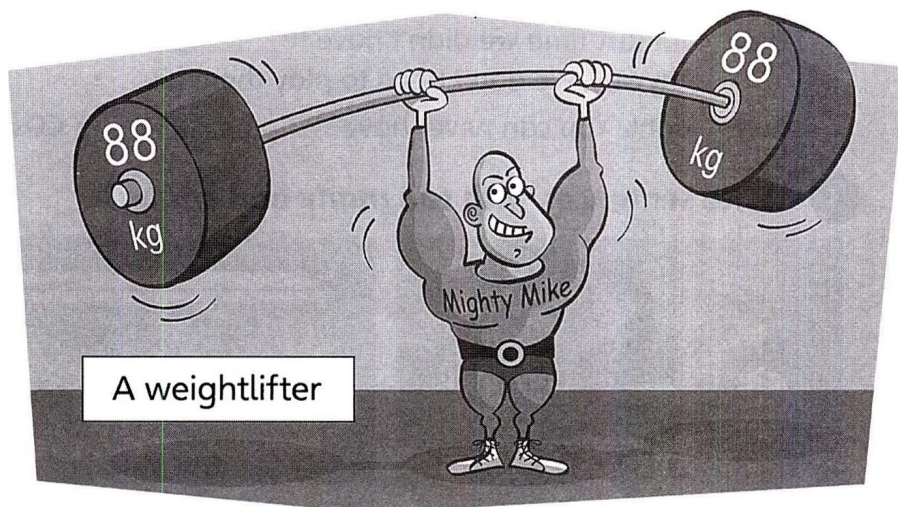

**4** Match the rhyming words.

- |           |   |                                     |        |
|-----------|---|-------------------------------------|--------|
| 1 high    | a | <input type="checkbox"/>            | graph  |
| 2 laugh   | b | <input type="checkbox"/>            | stuff  |
| 3 through | c | <input checked="" type="checkbox"/> | fly    |
| 4 caught  | d | <input type="checkbox"/>            | zoo    |
| 5 enough  | e | <input type="checkbox"/>            | bought |

- |             |   |                          |       |
|-------------|---|--------------------------|-------|
| 6 light     | f | <input type="checkbox"/> | plate |
| 7 eight     | g | <input type="checkbox"/> | show  |
| 8 thought   | h | <input type="checkbox"/> | white |
| 9 cough     | i | <input type="checkbox"/> | short |
| 10 although | j | <input type="checkbox"/> | off   |

**5**  Listen, check and say the words.



**1 Make sentences.**

1 tell / switch / for / can / me / what / is / you / this / ?

Can you tell me what this switch is for?

2 machine / you / is / tell / can / me / this / what / ?

3 me / button / for / tell / this / can / blue / is / you / what / ?

4 does / me / can / lever / tell / what / you / this / ?

**2 Put the dialogue in order.**

Bradley The green button?

Bradley Ah, to cook them. And can you tell me what this switch is for?

1 Bradley Can you tell me what this machine is?

Bradley Mmm, I like soup. Can you tell me what this lever does?

Bradley I love your machine. Can I try some soup now?

Professor When you press that lever, all the vegetables fall into hot water.

Professor Yes, when you press the green button, the soup is put into cans and you can drink it.

Professor Certainly. It makes lots of different vegetable soups.

Professor It's for starting the knives inside. They cut up all the vegetables. And finally you press the green button.

Professor Certainly. Here you are.

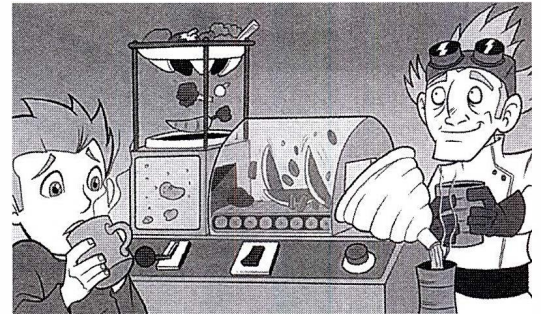

**3 Look at the pictures. Write questions with *is*, *does* and *is for*. Answer them with your own ideas.**

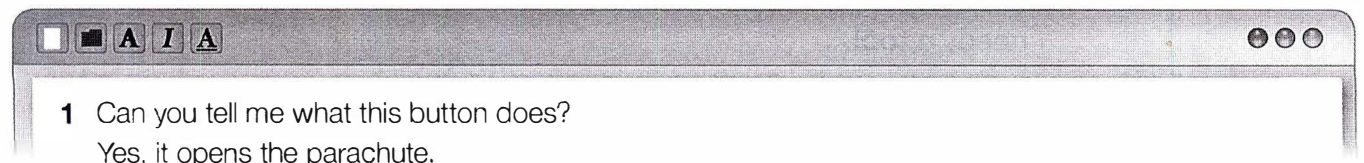
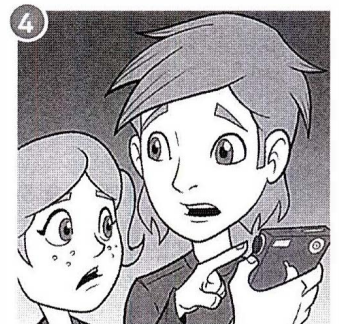
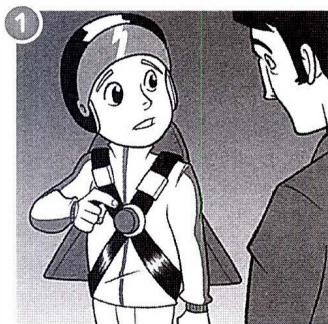

**1 Remember the story. Match the sentence halves.**

- |                            |                            |                                       |
|----------------------------|----------------------------|---------------------------------------|
| 1 The painting machine     | a <input type="checkbox"/> | should change how people look.        |
| 2 The Homework Express     | b <input type="checkbox"/> | should move things about the room.    |
| 3 The tele-transporter     | c <input type="checkbox"/> | should answer questions.              |
| 4 The hairdressing machine | d <input type="checkbox"/> | 1 should change the colour of things. |

**2 Look at the pictures. Complete the summary with the words for five of the objects.**

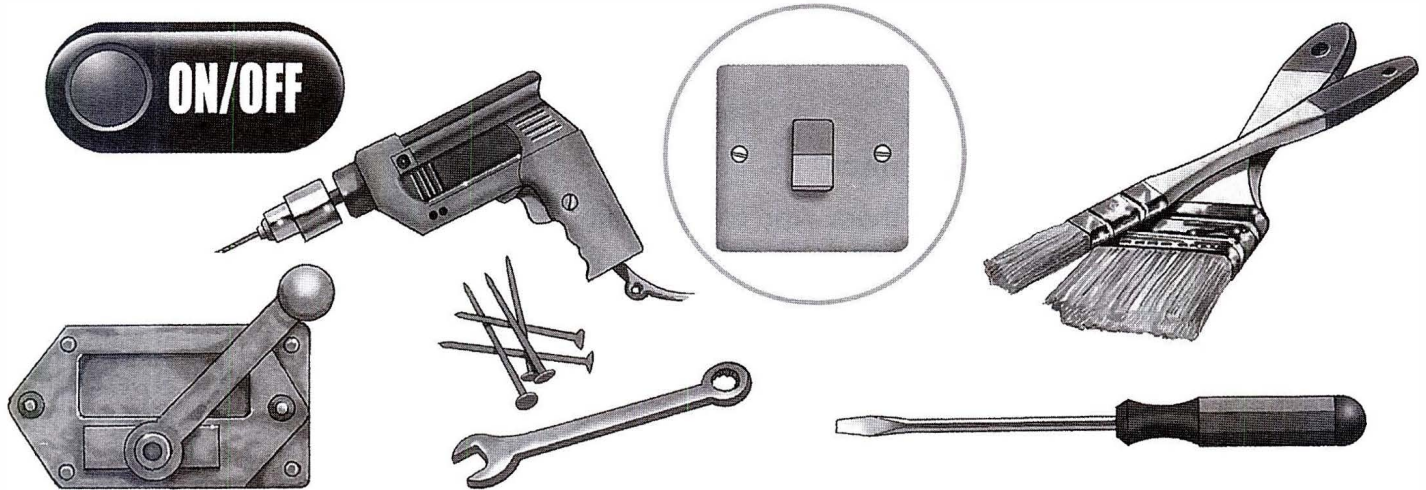

The professor shows the children his painting machine. He asks them to choose a colour for the chair. They choose red and yellow spots. The professor pushes a <sup>(1)</sup> switch and the <sup>(2)</sup> \_\_\_\_\_ es on the machine paint the cat green and blue instead. Next, he shows them the Homework Express. He asks them to choose a subject, so they pick Maths and they give the professor a sum. He types it into the machine and the answer 'Paris' appears.

The next machine which he shows them is the tele-transporter. You put an object in it, press a <sup>(3)</sup> \_\_\_\_\_ and the object appears on the other side of the room. Unfortunately, his experiment with a bike doesn't work and he'll need to use his <sup>(4)</sup> \_\_\_\_\_. Finally, he shows them a hairdressing machine, but Phoebe doesn't want to try it out. Patrick asks him about another machine. The professor tells him not to touch it, but it's too late. Patrick pulls the <sup>(5)</sup> \_\_\_\_\_ and the gate appears.

**3 Complete the sentences with the correct name.**

- 1 Phoebe chooses the colours for the chair.
- 2 \_\_\_\_\_ asks about the Homework Express.
- 3 \_\_\_\_\_ chooses the sum for the Homework Express.
- 4 \_\_\_\_\_ needs a tool.
- 5 \_\_\_\_\_ wants Phoebe to try the hairdressing machine.
- 6 \_\_\_\_\_ tells the professor that they know what the last machine does.



**1 Think!** Here are other wrong answers from the Homework Express. Match the answers with the questions that it was trying to answer.

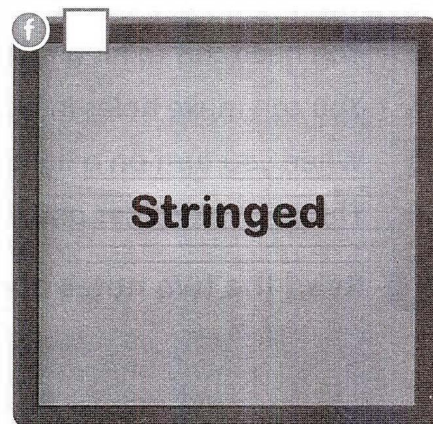
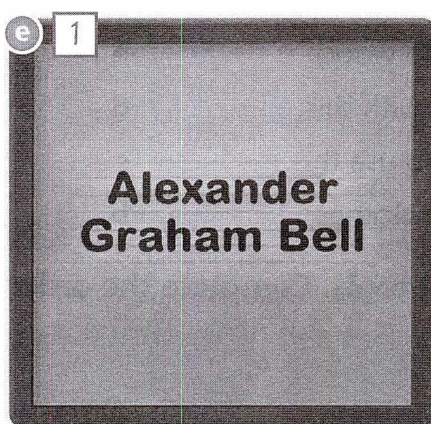
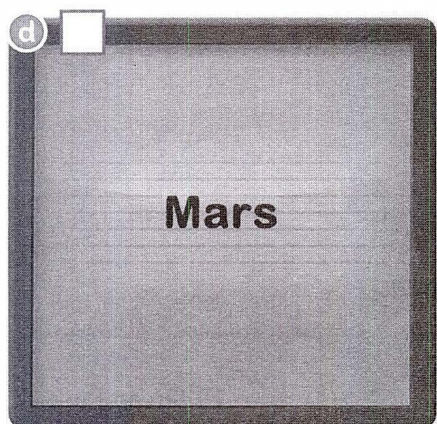
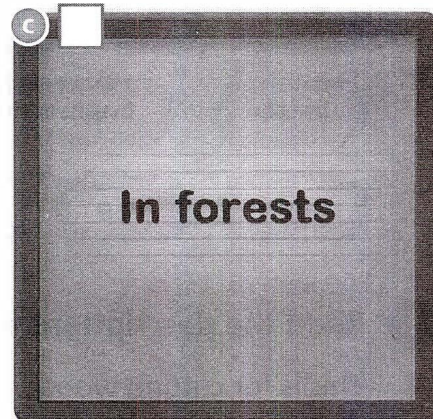
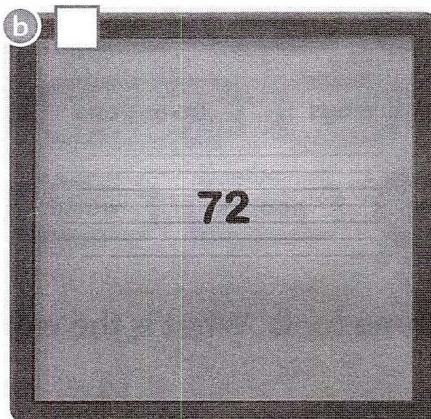
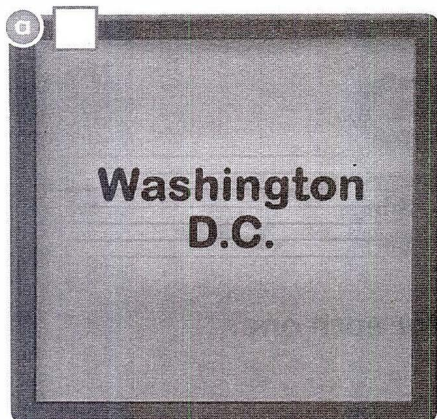

- |                                 |  |
|---------------------------------|--|
| 1 Who invented the plane?       | 4 What kind of instrument is a trumpet?          |
| 2 What is 9 x 9?                | 5 Where do sharks live?                          |
| 3 What is the capital of Italy? | 6 What's the biggest planet in the solar system? |

**2** The answers from the Homework Express in Activity 1 are all wrong, of course. Write the correct answers.

- |                         |         |
|-------------------------|---------|
| 1 Alberto Santos-Dumont | 4 _____ |
| 2 _____                 | 5 _____ |
| 3 _____                 | 6 _____ |

**3** Look at the machine's wrong answers in Activity 1. Write correct questions.

- a What is the capital of the USA?
- b \_\_\_\_\_
- c \_\_\_\_\_
- d \_\_\_\_\_
- e \_\_\_\_\_
- f \_\_\_\_\_







You will hear some information about a museum. Listen and complete the notes.

# GREAT INVENTIONS MUSEUM

YOU CAN SEE

**Downstairs**

Red Room: (1) Old typewriters

Green Room: (2) \_\_\_\_\_

**Upstairs**

Left Gallery: (3) \_\_\_\_\_

Right Gallery: More than 300

(4) \_\_\_\_\_

Price of guidebook: (5) \_\_\_\_\_

Museum closes at: (6) \_\_\_\_\_



2 Which notice (A–H) says this (1–6)? Write the correct letter.

**A** Knock before entering

**B** Press to switch on

**C** Laboratory opens at 8 a.m.

**D** FIRE EXIT

**E** PULL LEVER TO STOP

**F** ARE YOU WEARING YOUR GOGGLES?

**G** KEEP QUIET Experiment in progress

**H** All children must be with an adult

- 1 If there is an emergency, go out of this door.
- 2 You must not make any noise at the moment.
- 3 You must wear eye protection.
- 4 You can't walk straight into the laboratory.
- 5 Work starts in the morning.
- 6 This button is for starting the machine.

D



1 Choose the correct words.

- 1 We use a lever if we want to lift / force something that is very heavy. You need to use less load / force when you lift something up with the help of a lever.
- 2 People have used levers / lift for thousands of years.
- 3 If you try to lift up a heavy load / force without a lever, you'll hurt your back.
- 4 The place where the lever turns is called a lift / pivot.

2 Match the pictures with the sentences in Activity 1.

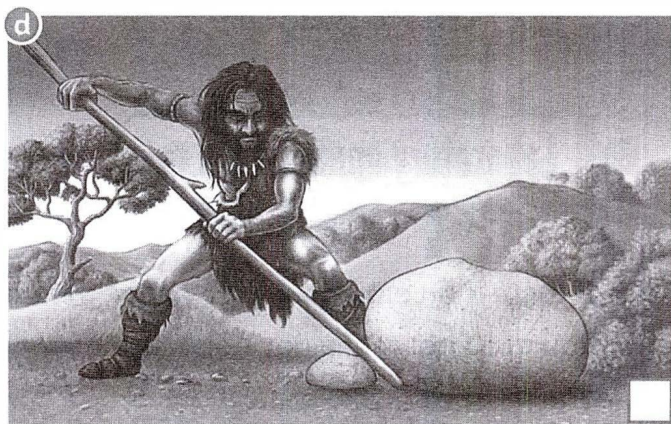
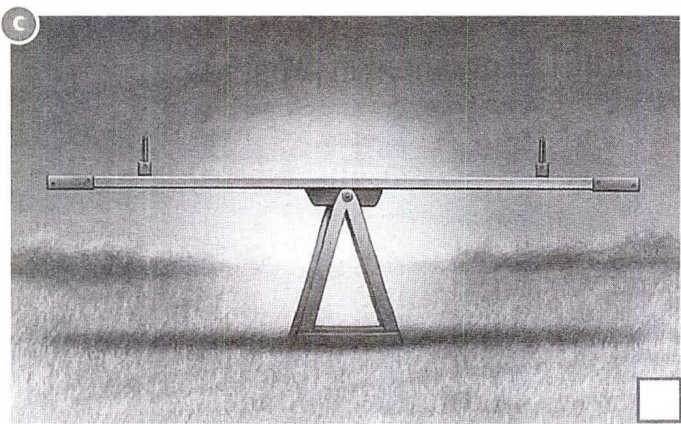
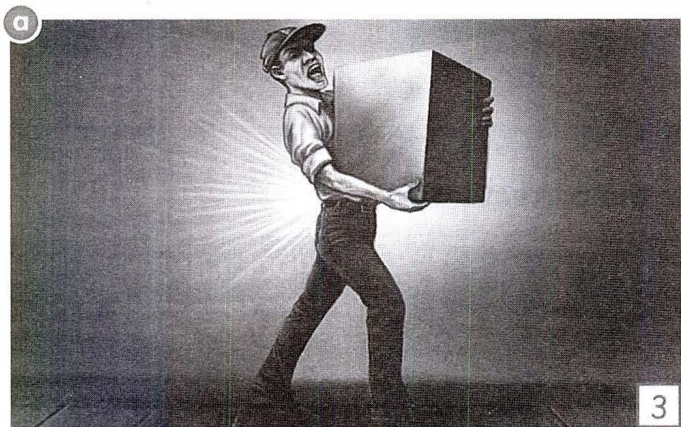

3 Which of the pictures in Activity 2 show pivots? Circle the pivots.



1 Tick (✓) the pictures where a lever is used.

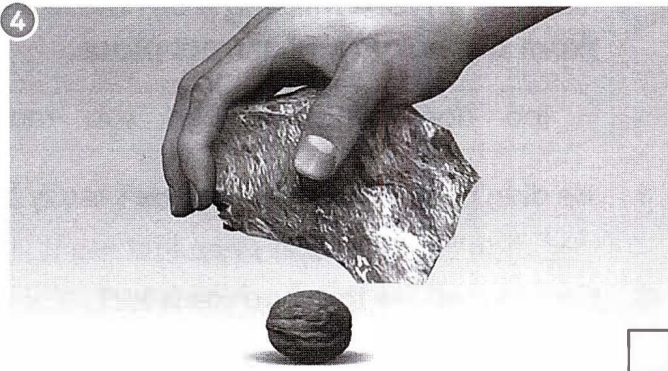
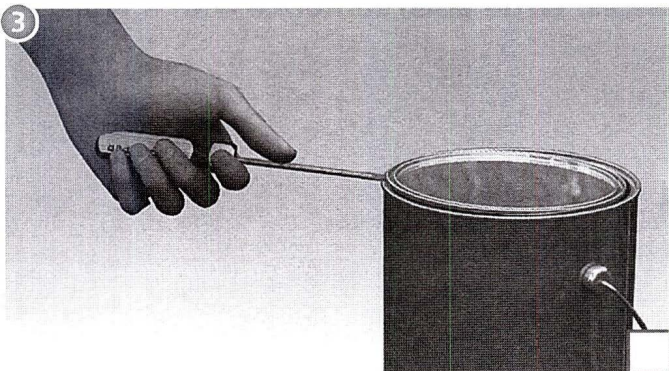
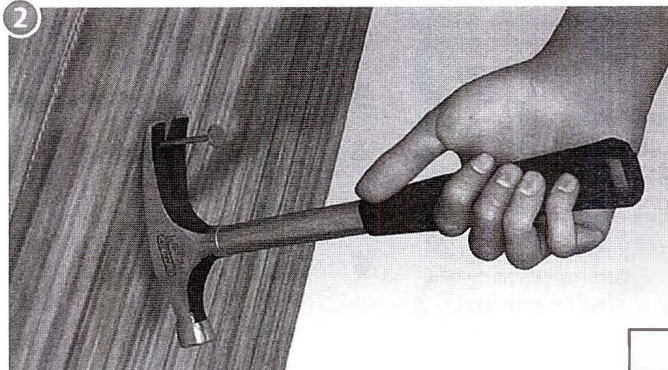
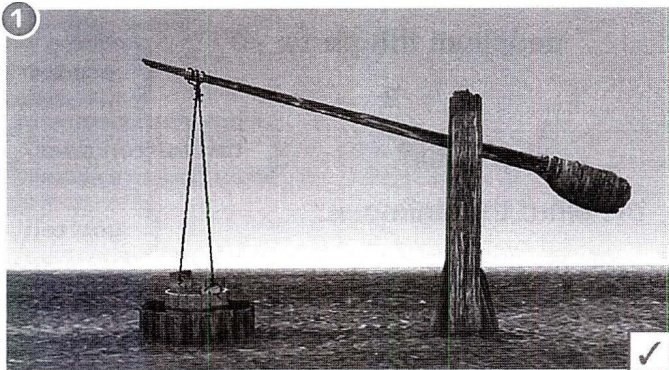

2 Ryan and Jenna are doing an experiment. Look at the pictures and answer the questions.

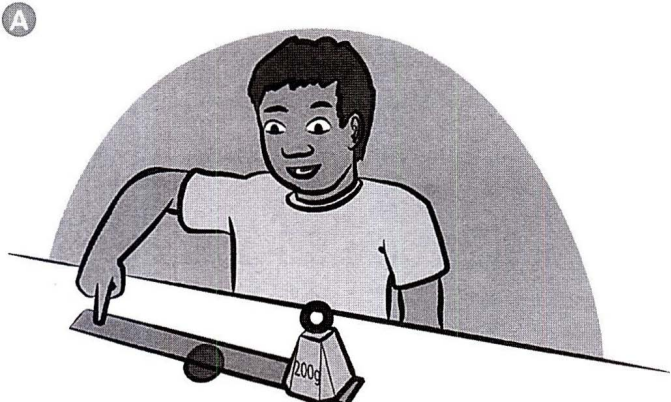

1 What is the same in both pictures? What is different?

\_\_\_\_\_

2 Who has to use more force: Ryan or Jenna?

\_\_\_\_\_

3 Who will push the load higher: Ryan or Jenna?

\_\_\_\_\_

**1 Choose six words or phrases to complete the sentences.**

<b>what this lever</b>	1 We haven't <i>got enough</i> food for everyone.	<b>hasn't got</b>
<b>too many</b>	2 There are _____ people at this party.	<b>are too</b>
<b>haven't got</b>	3 Can you tell me what _____ ?	<b>this button does</b>
<b>tell me</b>	4 Can you tell me _____ is for?	<b>you tell</b>
<b>got enough</b>	5 Can _____ me what this animal is?	<b>can you</b>
	6 I _____ enough time to finish my homework.	

**2 There is a word missing from these sentences. Write each sentence with a word from the box in the correct place.**

too does what ~~enough~~ you many

- 1 He didn't get sleep last night. He's really tired.  
He didn't get enough sleep last night. He's really tired. \_\_\_\_\_
- 2 Can you tell me this machine is for?  
\_\_\_\_\_
- 3 She's got many posters and nowhere to put them all.  
\_\_\_\_\_
- 4 Can tell me what this is?  
\_\_\_\_\_
- 5 I've got too clothes. I need to give some away.  
\_\_\_\_\_
- 6 Can you tell me what this switch?  
\_\_\_\_\_

**3 Complete the sentences with your own ideas.**

- 1 I've got too \_\_\_\_\_
- 2 I haven't got enough \_\_\_\_\_
- 3 \_\_\_\_\_ does?
- 4 Can you tell me \_\_\_\_\_ ?
- 5 \_\_\_\_\_ too much homework.
- 6 \_\_\_\_\_ is for?





# 7

# This is Houston

1 Look at the pictures. Complete the words.



1 countdown  
clock

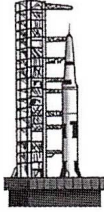

2 launch  
pad

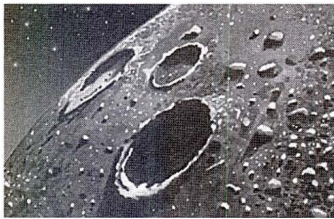

3 crater



4 helmet

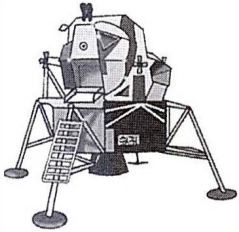

5 lunar  
module

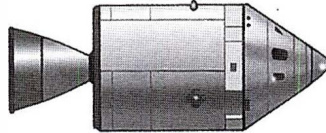

6 screen  
control



7 satellite



8 space

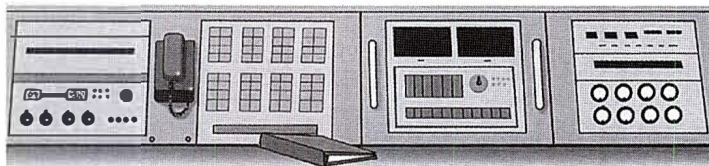

9 control panel

2 Correct one moon landing word in each sentence.

- There was something wrong with the ~~headset~~ and the astronauts didn't know the temperature.  
control panel
- When the space capsule reached zero, the rocket took off.  
launch pad
- They couldn't speak to the astronaut because he wasn't wearing his launch pad.  
helmet
- The astronauts put on their control panels and climbed into the rocket.  
lunar module
- The lunar module landed in a large countdown clock on the moon.  
crater
- Before they could take off, the astronauts sat in the crater and checked the control panel.  
control panel

3 Match the sentence halves.

- The three children have landed
  - The photo on the wall
  - It was taken
  - One of the engineers
  - Patrick explains that
  - A security officer thinks that
- shows the Saturn V rocket.
  - asks them what they are doing.
  - they could be spies.
  - in 1969, in Houston, Texas.
  - they are from the future.
  - four days ago.

d



**1 Complete the sentences with the gerund of the verbs in brackets.**

- 1 Living \_\_\_\_\_ in a space capsule for weeks isn't easy. (live)
- 2 \_\_\_\_\_ as a space pilot takes many years. (train)
- 3 \_\_\_\_\_ in space is difficult. (eat)
- 4 \_\_\_\_\_ a perfect landing needs practice. (make)
- 5 \_\_\_\_\_ in the space capsule is uncomfortable. (sleep)
- 6 \_\_\_\_\_ home to your family is wonderful. (come)

**2 Write sentences for the pictures.**

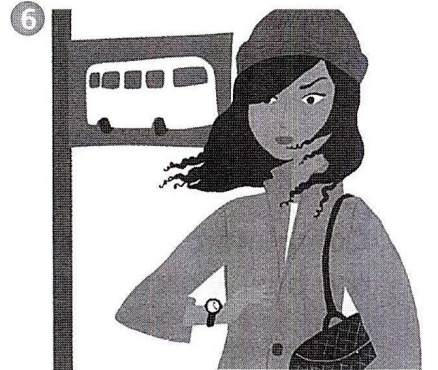
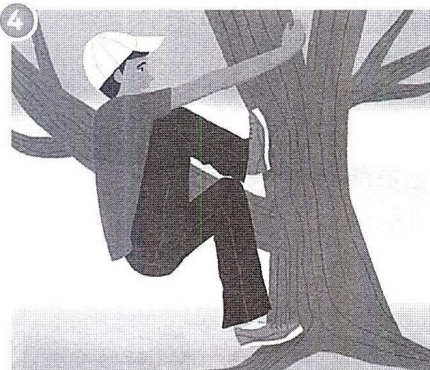
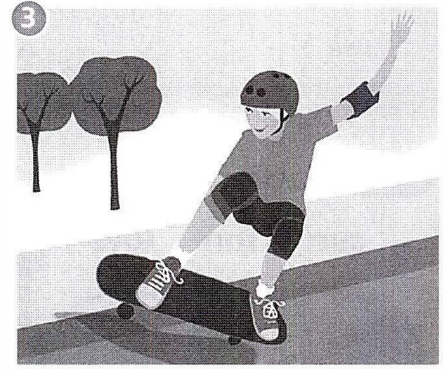
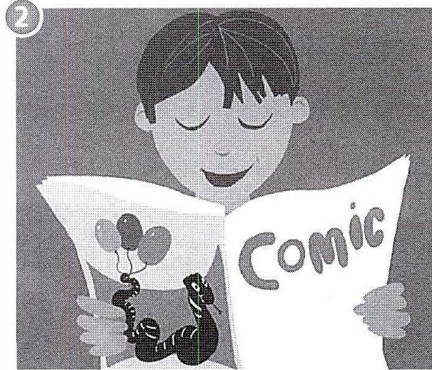
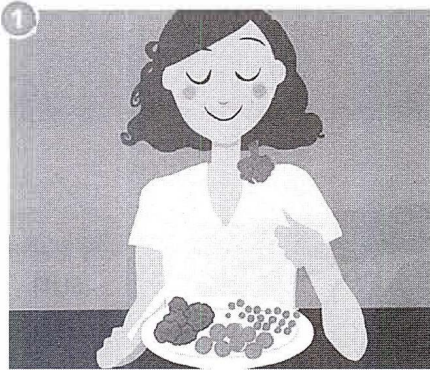

- |                                       |                    |
|---------------------------------------|--------------------|
| 1 Eating vegetables is _____ healthy. | 4 _____ hard.      |
| 2 _____ fun.                          | 5 _____ dangerous. |
| 3 _____ exciting.                     | 6 _____ boring.    |

**3 Write six sentences about yourself. Use different adjectives in each sentence and the gerund of some of the verbs from the box.**

play watch cook help read study for a test tidy write do





**1 Remember the song. Complete the report with the words from the box.**

went happy didn't so talked stars radio about flying tired

**GROUND CONTROL MISSION LOG:** February 1970

When we <sup>(1)</sup> talked to Commander Graham this morning, he seemed very <sup>(2)</sup> \_\_\_\_\_. He was enjoying <sup>(3)</sup> \_\_\_\_\_ fast and looking at the view. He really liked watching the <sup>(4)</sup> \_\_\_\_\_ come up. Then he was <sup>(5)</sup> \_\_\_\_\_, so he <sup>(6)</sup> \_\_\_\_\_ to bed. The next time we called him on the radio, he <sup>(7)</sup> \_\_\_\_\_ answer. Was he sleeping? Was his <sup>(8)</sup> \_\_\_\_\_ working? We aren't sure, <sup>(9)</sup> \_\_\_\_\_ we're worried <sup>(10)</sup> \_\_\_\_\_ him.

**2** <sup>CD 3</sup> <sub>33</sub> Listen and say the words.

sun son love

**Phonics tip**

The *u* sound, as in *sun*, can be spelled in different ways.

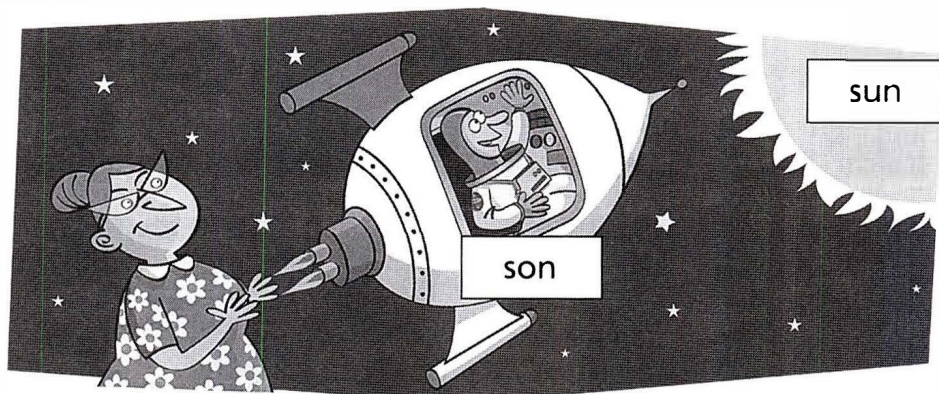

**3 Complete the sentences with the words from the box. Match them with the pictures.**

monkeys money doesn't  
London front lovely

- 1 There are so many fun things to do in London .
- 2 The \_\_\_\_\_ at the zoo are funny.
- 3 Gus \_\_\_\_\_ like running in the hot sun.
- 4 My mum's got a \_\_\_\_\_ new jumper.
- 5 It's very dangerous to walk in \_\_\_\_\_ of a bus at a bus stop.
- 6 My older cousin gave me some \_\_\_\_\_ for my birthday.

e

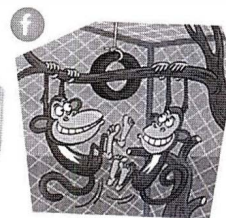
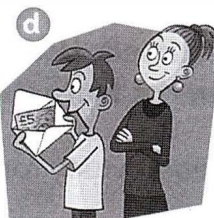
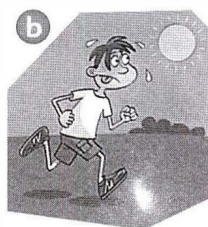

**4** <sup>CD 3</sup> <sub>34</sub>

**Listen, check and say the sentences.**



1 Complete the sentences in reported speech with the past simple of the verbs in brackets.

- 1 The alien said that she was from planet FX 344. (be)
- 2 She said that her name \_\_\_\_\_ Jezrak. (be)
- 3 The alien said that she \_\_\_\_\_ 112 languages. (speak)
- 4 She said that a journey to Earth \_\_\_\_\_ four years. (take)
- 5 The alien said that she \_\_\_\_\_ sixteen instruments. (play)
- 6 She said that she \_\_\_\_\_ in a house made of silver on FX 344. (live)

2 Complete the sentences with reported speech.

- 1 'I really love broccoli soup.'  
She said that she really loved broccoli soup.
- 2 'I watch TV every night for three hours.'  
He said that he \_\_\_\_\_.
- 3 'I feed the cat every morning at seven.'  
She said that she \_\_\_\_\_.
- 4 'I play football every Saturday afternoon.'  
He said that he \_\_\_\_\_.
- 5 'I take the dog for a walk every evening.'  
She said that she \_\_\_\_\_.
- 6 'I always have a snack after school.'  
She said that she \_\_\_\_\_.

3 Read the interview with Jezrak's friend. Complete the journalist's article.

**Journalist** So, you're Jezrak's friend Zaprax and you're from FX 344 too. Have you got a family?

**Zaprax** Yes, I've got a wife and two boys.

**Journalist** Do the children go to school?

**Zaprax** No, because robots give the children lessons at home.

**Journalist** What sort of work do you do?

**Zaprax** I'm a scientist and a pilot.

**Journalist** So you've got two jobs?

**Zaprax** Yes, everyone has got two jobs.

**Journalist** Isn't it difficult to have two jobs?

**Zaprax** No, it isn't. We only need to sleep for three hours at night.

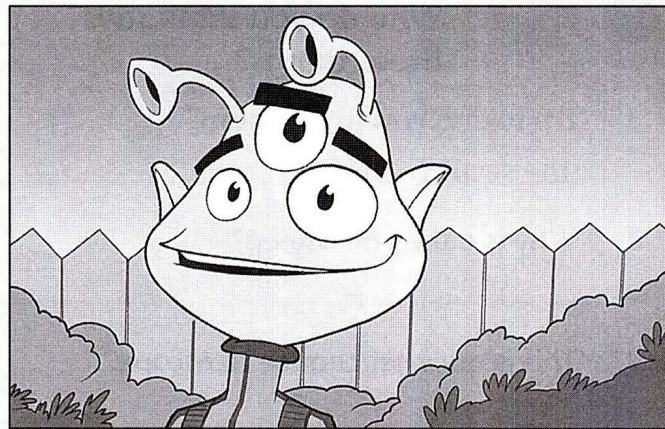

Yesterday I talked to Zaprax, another alien from FX 344. I asked about his family and he said that he <sup>(1)</sup> had a wife and two boys. I was interested to find out about schools on FX 344, but Zaprax said that <sup>(2)</sup> \_\_\_\_\_ at home. When I asked about his work, Zaprax said that he <sup>(3)</sup> \_\_\_\_\_ : he's a scientist and a pilot. I was surprised, but he explained that on FX 344, <sup>(4)</sup> \_\_\_\_\_. This sounded like very hard work to me, but Zaprax said that it <sup>(5)</sup> \_\_\_\_\_ difficult because they only <sup>(6)</sup> \_\_\_\_\_ for three hours at night.

**1 Remember the story. Match the sentence halves.**

- 1 The men think that the children are spies and
- 2 Suddenly one of the engineers feels dizzy and
- 3 Then the security officer sits down and
- 4 Soon the whole control room is asleep and the
- 5 Phoebe realises that there was something
- 6 They hear a voice calling the control room and
- 7 The children sit in front of a computer and they
- 8 Alex tells Neil what the problem is and
- 9 The engineers wake up and
- 10 The engineers want to know how Alex did it,

- a  children wonder what is happening.
- b  in their tea.
- c  put on the headsets.
- d  so he tells them about Moonlanding 2000.
- e  he sits down and falls asleep.
- f  Neil Armstrong tells them how Alex saved the day.
- g  he helps him to leave the moon.
- h  they want to lock them up.
- i  they know that they must help Neil Armstrong.
- j  he falls asleep too.

**2 Think! Who do you think says these things?**

- 1 'I'm taking you to my room.'  
the security officer \_\_\_\_\_
- 2 'Why are they all asleep?'  
\_\_\_\_\_
- 3 'This is our best chance to escape.'  
\_\_\_\_\_
- 4 'Hello ... Hello ... Is there anyone there?'  
\_\_\_\_\_
- 5 'I remember this bit from the game.'  
\_\_\_\_\_
- 6 'Why are you wearing my headset?'  
\_\_\_\_\_

**3 Complete the computer game blurb.**

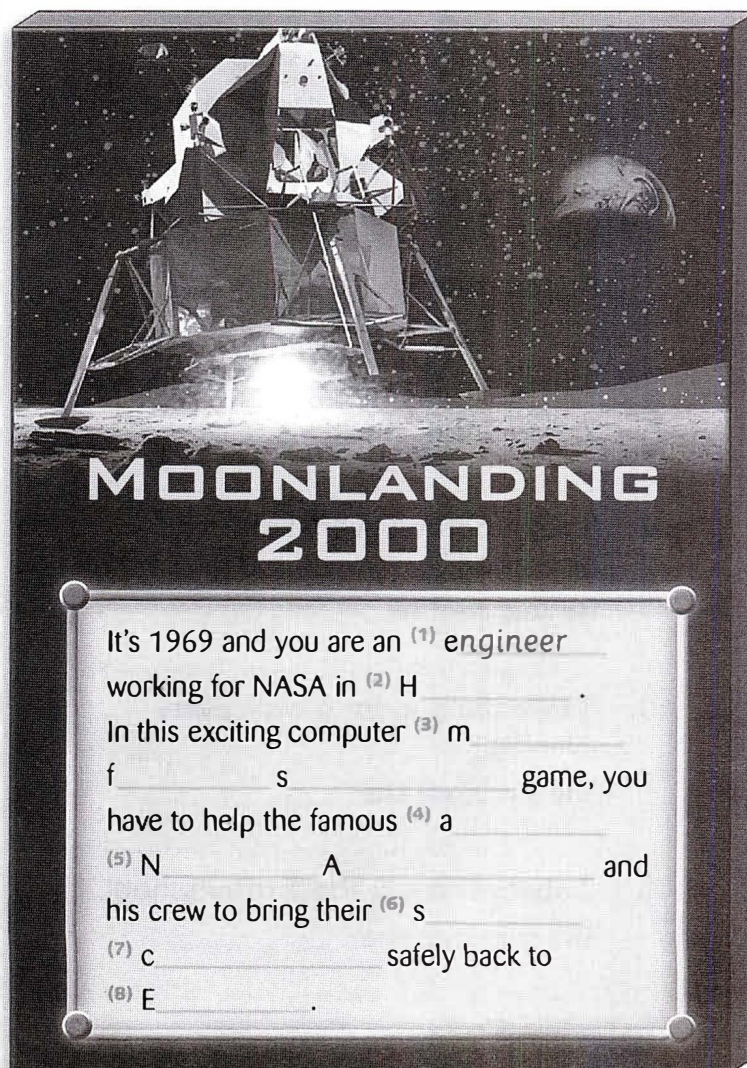

**MOONLANDING 2000**

It's 1969 and you are an <sup>(1)</sup> engineer working for NASA in <sup>(2)</sup> H \_\_\_\_\_ . In this exciting computer <sup>(3)</sup> m \_\_\_\_\_ f \_\_\_\_\_ s \_\_\_\_\_ game, you have to help the famous <sup>(4)</sup> a \_\_\_\_\_ <sup>(5)</sup> N \_\_\_\_\_ A \_\_\_\_\_ and his crew to bring their <sup>(6)</sup> s \_\_\_\_\_ <sup>(7)</sup> c \_\_\_\_\_ safely back to <sup>(8)</sup> E \_\_\_\_\_ .



- 1 Read the sentences in the box. Who said these things in the story? Complete the newspaper article with reported speech.

I play it for hours. I feel dizzy. I'm really good at it.  
We need help. It's a computer game.

### Strange happenings at NASA

Three mysterious children have saved Neil Armstrong's historic mission from disaster. But who are they? The children were found in the NASA control room. Nobody knew where they came from. The security officer was going to lock them in his room when he said that he <sup>(1)</sup> felt dizzy . In the next few minutes all the NASA engineers fell asleep at their desks. Only the children were awake when Armstrong said over the loudspeakers that they <sup>(2)</sup> \_\_\_\_\_ . For the next half an hour, one



of the boys helped Armstrong and when the engineers woke up, the lunar module was safely off the moon. When the engineers asked the boy how he knew what to do, he said that it <sup>(3)</sup> \_\_\_\_\_ , Moonlanding 2000. He said that he <sup>(4)</sup> \_\_\_\_\_ and that he <sup>(5)</sup> \_\_\_\_\_ . The children then walked into a yellow light and disappeared. Humans? Aliens? Ghosts? Will we ever know what really happened?

- 2 Think! Which of the four engineers is the spy?



The spy is number \_\_\_\_\_ because \_\_\_\_\_ .

**1 Complete the email. Write one word for each space.**

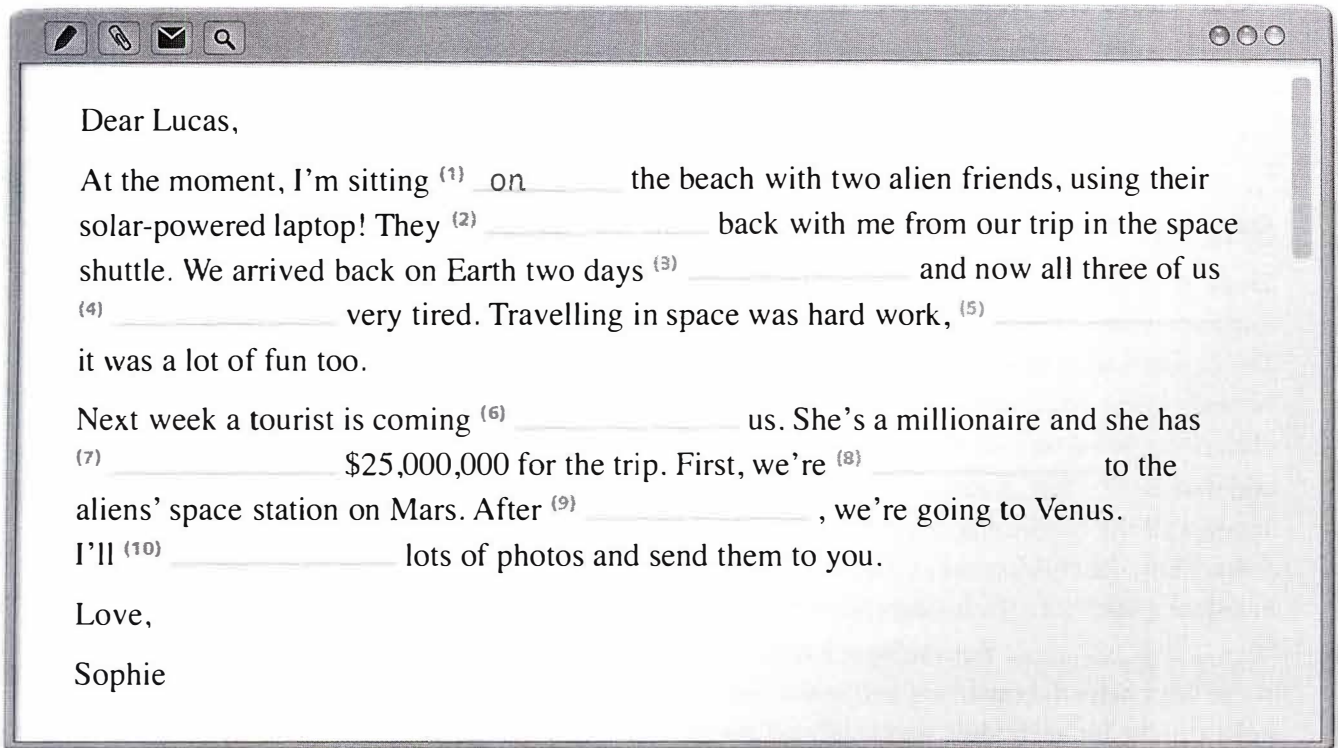

**2 Complete the conversation between the interviewer and the space tourist. Choose the correct letter (A–H).**

**Interviewer** How was your trip?

**Space tourist** (1)  C

**Interviewer** Did you really land on Venus?

**Space tourist** (2)

**Interviewer** How much was the flight?

**Space tourist** (3)

**Interviewer** Would you go again?

**Space tourist** (4)

**Interviewer** Where would you like to go next?

**Space tourist** (5)

**Interviewer** Why Saturn?

**Space tourist** (6)

**A** I'm not going to tell you, but believe me, it was very expensive!

**B** To Saturn.

**C** It was fantastic!

**D** You're welcome!

**E** No, I was perfectly fine. I trained 600 hours for this flight.

**F** Yes, I'd love to. Actually, I've already made plans.

**G** Because I'd like to study the rings there.

**H** Of course we did. That's what I paid for!



**1 Think!** Put Commander Cormack's thoughts in order.

- I'm sure I recognise those two monkeys.
- Humans have done some bad things in the past. We should say sorry.
- That gadget's amazing. I can understand every word!
- We're nearly there. Time to contact the control room.
- They welcomed us, so I must explain that we don't want to fight them.

**2 Values** What can we learn from the story? Colour the words.

Knowing    Asking    when    what    to    for    say

remember    hello    sorry    is    are    bad    important    .

**3** Look at the pictures and write the story.

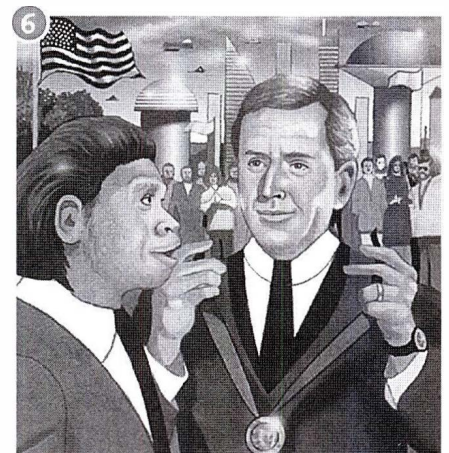
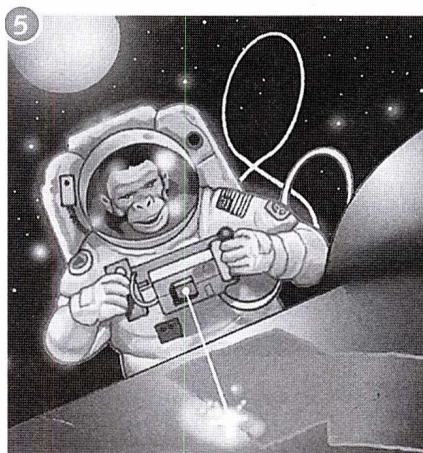
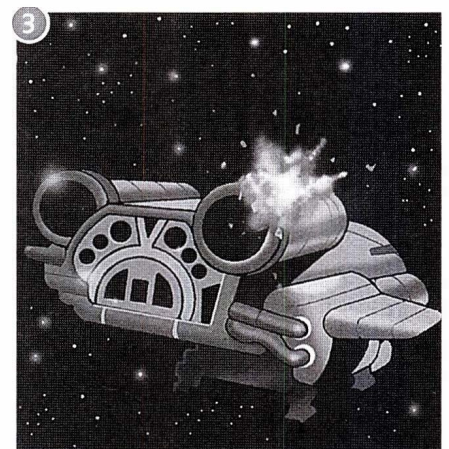
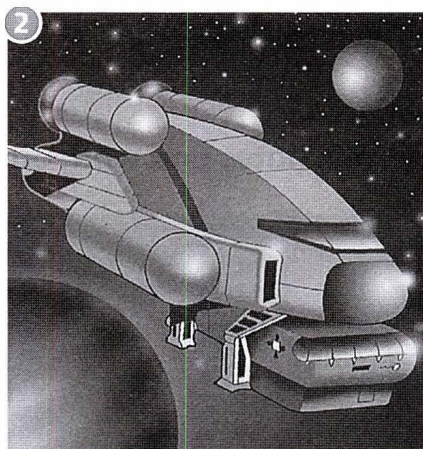
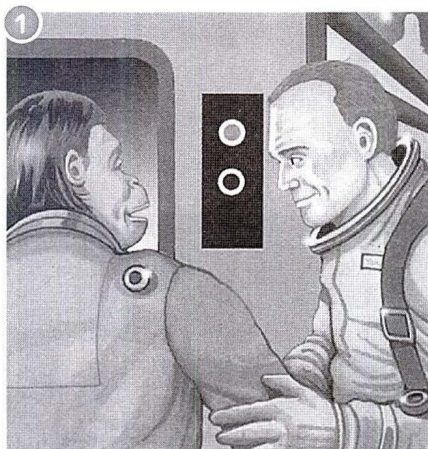

Commander Cormack and one of the monkeys from Pluto got into ...



**1 Complete the text with the times and the distances from the box.**

13 hours   4.5 billion years   130 days   120 km/h   384,400 km   27 days

The moon is <sup>(1)</sup> 4.5 billion years old. Most people believe that it is slightly younger than Earth, although no-one is sure how it was created. It takes the moon more than <sup>(2)</sup> \_\_\_\_\_ to orbit Earth. The moon is much closer to Earth than Mars. It is <sup>(3)</sup> \_\_\_\_\_ from Earth. It takes a rocket about <sup>(4)</sup> \_\_\_\_\_ to reach the moon. Imagine you're driving on a road from Earth to the moon. You'll need about <sup>(5)</sup> \_\_\_\_\_ to reach the moon by car ... but you'll need to travel at about <sup>(6)</sup> \_\_\_\_\_ without stopping!



**2** CD4  
07%

**Think!**

**Listen to the interview.**

**Complete the boy's notes and work out his answer.**

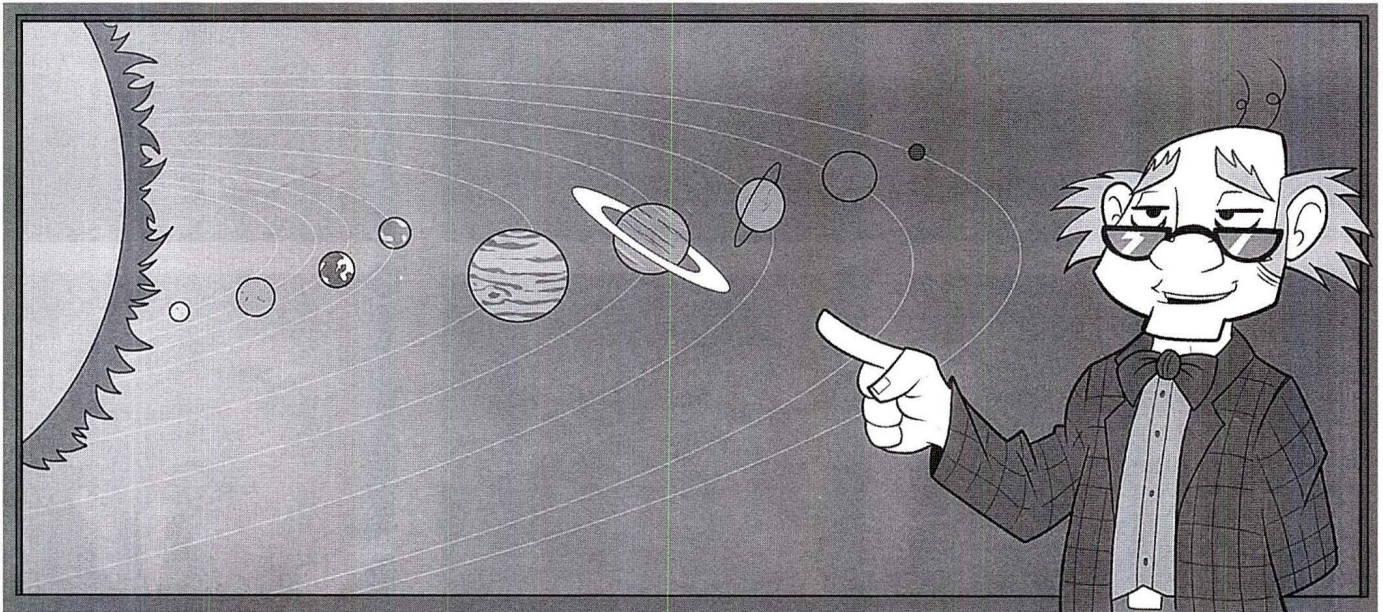

M 0 \_\_\_\_\_, V \_\_\_\_\_, E \_\_\_\_\_, Ma \_\_\_\_\_, J \_\_\_\_\_, S \_\_\_\_\_, U \_\_\_\_\_,  
N \_\_\_\_\_, P (dwarf planet) \_\_\_\_\_

The answer is: \_\_\_\_\_



**1 Match the words with the definitions.**

- |           |                            |  |
|-----------|----------------------------|--|
| 1 gravity | a <input type="checkbox"/> | when we see more of the moon                   |
| 2 waning  | b <input type="checkbox"/> | become smaller                                 |
| 3 waxing  | c <input type="checkbox"/> | the force that makes things fall to the ground |
| 4 orbit   | d <input type="checkbox"/> | turn   |
| 5 spin    | e <input type="checkbox"/> | when we see less of the moon                   |
| 6 shrink  | f <input type="checkbox"/> | go around something                            |

**2 Label the phases of the moon in the northern hemisphere with the phrases from the box.**

gibbous moon (waxing)   half moon (last quarter)   ~~new moon~~   crescent moon (waning)  
 gibbous moon (waning)   half moon (1st quarter)   full moon   crescent moon (waxing)

(1) new moon                      (3) \_\_\_\_\_                      (5) \_\_\_\_\_                      (7) \_\_\_\_\_

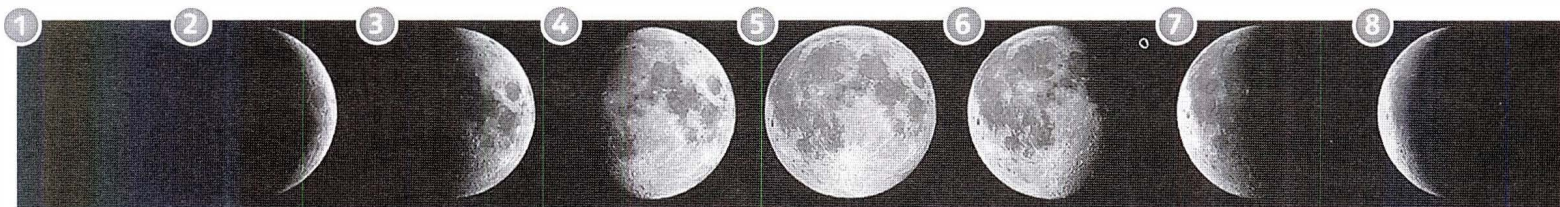

(2) \_\_\_\_\_                      (4) \_\_\_\_\_                      (6) \_\_\_\_\_                      (8) \_\_\_\_\_

**3 Think! Choose the correct words.**

On a sunny afternoon in the <sup>(1)</sup> summer / winter month of June,  
 My little sister pointed <sup>(2)</sup> up / down and shouted, 'There's the moon!  
 Over there, <sup>(3)</sup> above / below those trees! A great big <sup>(4)</sup> yellow / purple ball of cheese!  
 And then she <sup>(5)</sup> pulled / pushed my arm and said, 'Come and look, oh please!  
 I knew it really couldn't be, but I <sup>(6)</sup> stood up / sat down to go and see.  
 'That's the sun,' I said, 'because it's only half past <sup>(7)</sup> three / ten!'

**4** CD4 08 **Listen and check your answers. Say the poem.**

- 1 Make three sentences with the phrases in the diamond. Use three different phrases in each sentence.

Looking \_\_\_\_\_  
 \_\_\_\_\_  
 \_\_\_\_\_  
 \_\_\_\_\_  
 \_\_\_\_\_



- 2 Draw lines and complete the sentences with the words from the box.

drove said very putting jet pack flying

1 The alien said _____	spacesuit needs _____	an old car.
2 _____ to _____	that his grandma _____	exciting.
3 The alien said that she _____	dinosaurs _____	<u>practice</u> .
4 I said that _____	flew around on a _____	had three heads.
5 _____ on a _____	my dad _____	is _____ interesting.
6 Reading about _____	the moon is _____	_____ on her planet.

- 3 Complete the sentences with your own ideas.

- The alien said that he liked \_\_\_\_\_ .
- Reading \_\_\_\_\_ .
- The alien said that she \_\_\_\_\_ .
- Speaking \_\_\_\_\_ .
- The aliens said that they \_\_\_\_\_ .
- Travelling to \_\_\_\_\_ .





1 Complete the words with the letters from the igloo.

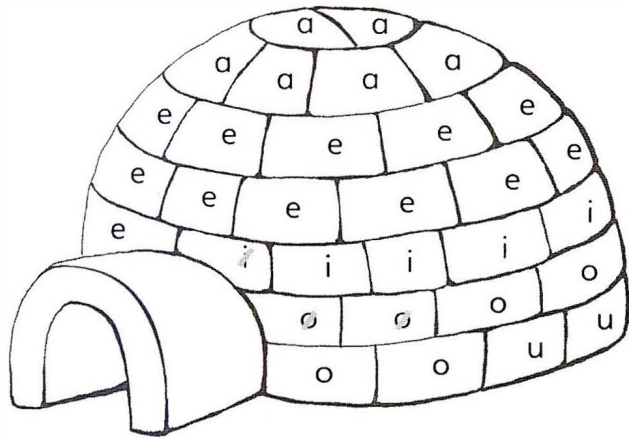

- |   |          |    |                 |
|---|----------|----|-----------------|
| 1 | igloo    | 6  | p l r b _ r     |
| 2 | s _ l    | 7  | n rth rn l ghts |
| 3 | m tt ns  | 8  | _ c fl _        |
| 4 | _ c b rg | 9  | p l r b _ r c b |
| 5 | sl dg _  | 10 | s _ l p p       |

2 Match the clues with the words from Activity 1.

- |   |                            |  |   |                          |                                 |
|---|----------------------------|--|---|--------------------------|---------------------------------|
| a | <input type="checkbox"/> 4 | a big block of ice in the sea              | f | <input type="checkbox"/> | a house made of ice bricks      |
| b | <input type="checkbox"/>   | a big white predator in the Arctic         | g | <input type="checkbox"/> | the baby of answer c            |
| c | <input type="checkbox"/>   | an adult animal that answer b likes to eat | h | <input type="checkbox"/> | you put these on your hands     |
| d | <input type="checkbox"/>   | this slides over the snow                  | i | <input type="checkbox"/> | ice floating on the sea         |
| e | <input type="checkbox"/>   | the baby of answer b                       | j | <input type="checkbox"/> | you see these in the Arctic sky |

3 Look at the pictures. Then choose words from Activity 1 to complete the story. You don't need to use all the words and you can use some more than once.

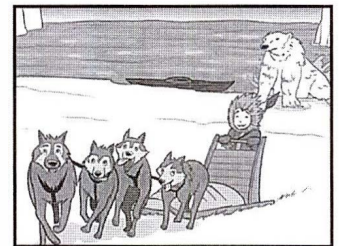
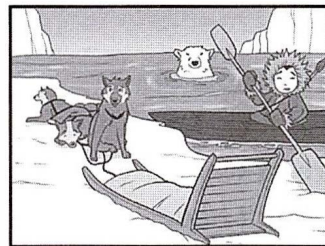

Akiak was hunting <sup>(1)</sup> seal s in his kayak. He saw one on an <sup>(2)</sup> \_\_\_\_\_, so he rowed closer. Suddenly he saw a <sup>(3)</sup> \_\_\_\_\_ in the water. It got onto the <sup>(4)</sup> \_\_\_\_\_ and the <sup>(5)</sup> \_\_\_\_\_ escaped quickly. The <sup>(6)</sup> \_\_\_\_\_ looked around and saw Akiak, who then turned the kayak and rowed hard. The <sup>(7)</sup> \_\_\_\_\_ jumped into the water and followed him. Akiak's dogs were waiting near the edge of the water with his <sup>(8)</sup> \_\_\_\_\_. When he reached the hard ice, he jumped on the sledge and the dogs ran as fast as they could.



**1 Choose the correct question tags.**

- 1 It isn't very cold, **is it** / **isn't it**?
- 2 Those polar bears are hungry, **are they** / **aren't they**?
- 3 The weather isn't getting colder, **is it** / **isn't it**?
- 4 Politicians are worried about climate change, **are they** / **aren't they**?
- 5 The ice in the Arctic is melting, **is it** / **isn't it**?
- 6 Seals aren't in danger, **are they** / **aren't they**?

**2 Complete the dialogue with the phrases from the box.**

are they   are they   aren't they   ~~isn't it~~   isn't it   isn't it   isn't it   is it

**Chloe**   Sorry I couldn't come yesterday, but I was doing my project on Antarctica.

**Thomas**   Antarctica? That's the North Pole,  
(1) isn't it ?

**Chloe**   No, it's the South Pole.

**Thomas**   But it's where polar bears live,  
(2) \_\_\_\_\_ ?

**Chloe**   No, they live at the North Pole.

**Thomas**   But it's a place where you find lots of whales, (3) \_\_\_\_\_ ?

**Chloe**   Yes, that's right. I've printed some great photos of them for my project.

**Thomas**   Whales aren't fish, (4) \_\_\_\_\_ ?

**Chloe**   No, they're mammals.

**Thomas**   And they aren't dangerous, (5) \_\_\_\_\_ ?

**Chloe**   Well, it depends who or what you are.

**Thomas**   What do you mean?

**Chloe**   A killer whale is dangerous, (6) \_\_\_\_\_ ? It eats seals.

**Thomas**   Seals? Are you sure? But seals are really small, (7) \_\_\_\_\_ ?

**Chloe**   No, they're pretty big actually.

**Thomas**   Oh ... hey Chloe, your project isn't finished yet, (8) \_\_\_\_\_ ?  
Tell me when it's ready, because I think I need to read it ...



**3 Complete the sentences with question tags.**

- 1 Alice's favourite food is spaghetti, isn't it ?
- 2 You aren't cold, \_\_\_\_\_ ?
- 3 Peter and Harry are in Year 6, \_\_\_\_\_ ?
- 4 New York isn't the capital of the USA, \_\_\_\_\_ ?
- 5 Mum is very angry about the window, \_\_\_\_\_ ?
- 6 I'm sure you're having a lot of fun, \_\_\_\_\_ ?

**1 Complete the dialogue with the phrases from the box.**

isn't it Did you say Can I just check something Just remind me aren't you

**Josh** Hi, Charlie. It's me – Josh. So, did you get it?

**Charlie** Erm, I'm not sure what you mean. <sup>(1)</sup> *Just remind me*, Josh.

**Josh** Your cousin's sledge. You said that you could borrow it. And it's one o'clock now, <sup>(2)</sup> \_\_\_\_\_? So I'm ready to go. What about you?

**Charlie** <sup>(3)</sup> \_\_\_\_\_?

**Josh** Check what?

**Charlie** Where are we going?

**Josh** To Bluebell Hill.

**Charlie** <sup>(4)</sup> \_\_\_\_\_ 'Bluebell Hill'?

**Josh** Yes, I did. Bluebell Hill. Oh, come on, Charlie. You're a bit slow today, <sup>(5)</sup> \_\_\_\_\_? We talked about this trip at break yesterday at school.

**Charlie** Oh, sorry, I remember now. Well, I can meet you in about half an hour, OK?

**2** <sup>CD 4</sup>  
<sup>14</sup> **Listen and say the words.**

weather    today  
holiday    computer

**Phonics tip**

In longer words, we need to stress one syllable more than the others.

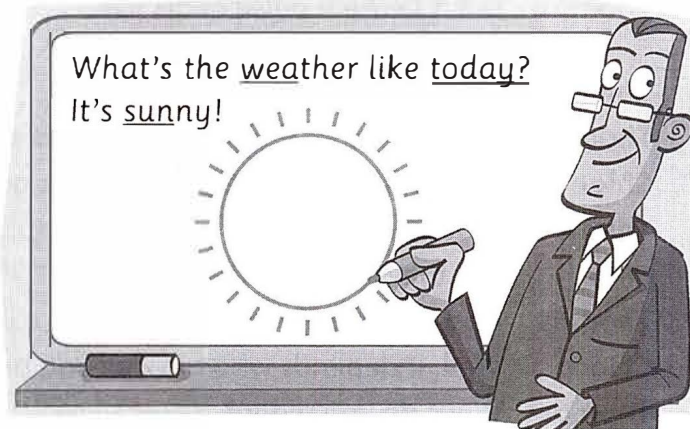

**3 Say the words in the box and write them in the correct syllable stress column.**

penguin across yesterday adventure  
mittens because problem remind  
grandparents depends animal forgotten  
suddenly tomorrow finished decided

<b>● ●</b> <b>weather</b>	<b>● ● ●</b> <b>today</b>	<b>● ● ● ●</b> <b>holiday</b>	<b>● ● ● ● ●</b> <b>computer</b>
penguin	across	yesterday	adventure

**Word watch**

The sound in the unstressed syllables is very short. This sound can be spelled in different ways, for example across, yesterday and computer.

**4** <sup>CD 4</sup>  
<sup>15</sup> **Listen, check and say the words.**



**1 Think! Put the lines in order.**

- The seals might be much further out on ice floes, so
- Because of this, many of them might die.
- the polar bears might have to swim much longer distances.
- 1 If the world gets warmer,
- they might not be strong enough to hunt every day.
- a lot of ice in the Arctic may melt.
- They might be tired when they come back to the coast and

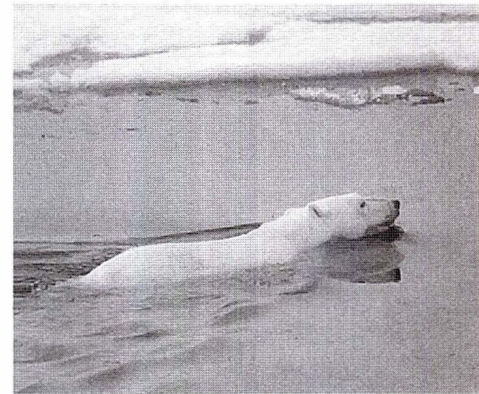

**2 Rewrite the sentences with *may*.**

- |  |                                       |
|--|---------------------------------------|
| 1 Perhaps Lucy's at home now.            | Lucy <i>may</i> be at home now _____. |
| 2 Perhaps Mum will buy a new car.        | Mum _____.                            |
| 3 Perhaps Jack's angry.                  | Jack _____.                           |
| 4 Perhaps Ella doesn't eat spinach.      | Ella _____.                           |
| 5 Perhaps it will be very cold tomorrow. | It _____.                             |
| 6 Perhaps Peter won't want to go.        | Peter _____.                          |

**3 Look at the pictures where Jack is dreaming about the future. Write sentences with *may* or *might* and the verbs from the box.**

win invite see get be ask

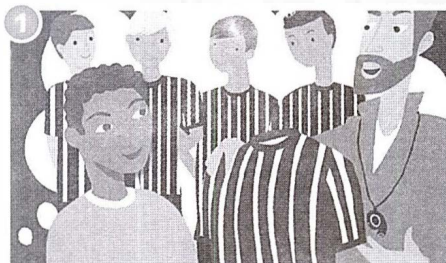

1 Mr Hay *might* ask me \_\_\_\_\_  
to join the team \_\_\_\_\_.

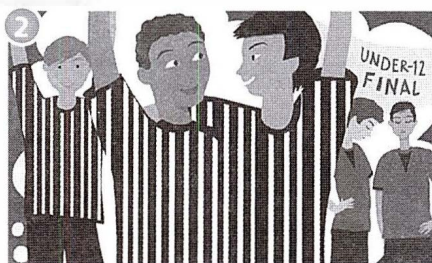

2 Our team \_\_\_\_\_.



3 We \_\_\_\_\_.

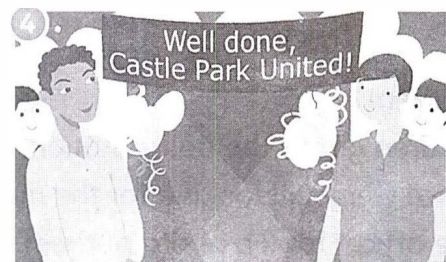

4 There \_\_\_\_\_.

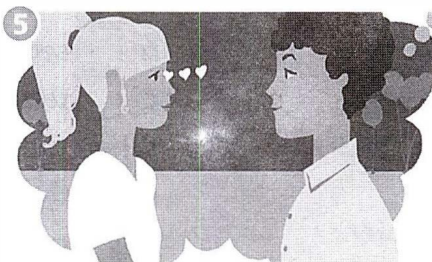

5 Jess \_\_\_\_\_.



6 Jess \_\_\_\_\_.

**1 Remember the story. Choose the correct answers.**

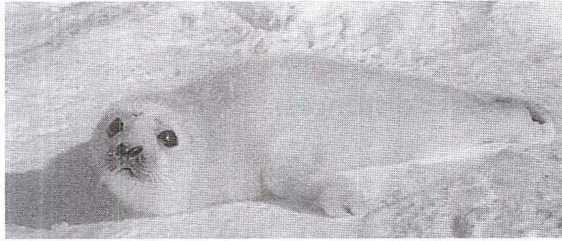

This is a seal <sup>(1)</sup> baby / cub / **pup**.  
Its other name is a <sup>(2)</sup> sealcoat /  
whitecoat / whitesal.



This is a <sup>(3)</sup> snow-go / snow sledge /  
ski-doo. <sup>(4)</sup> More than one person /  
Only one person can ride on it.

**2 Complete the summary with the missing letters. Each letter of the alphabet is missing once. Tick (✓) each letter when you use it in the grid below.**

The children see six seal pups on an ice floe. They are called white coats. Phoebe tells the others all about them and that they are protected in Canada. They hear a noise and they see two men get off a ski-doo. They are carrying big sticks because they are coming to fill the pups. The children jump onto the ice floe and push it out into the sea using their spaces. The two men try to get on the ice floe but they are too late. The pups are safe!

However, the children are now far from the beach. They can't get in and swim because the water is freezing. A helicopter appears above them. They wait and the pilot sees them. Soon they are all rescued. The children tell the pilot about the men and he radios the police station. The police quickly find the men and the children help to identify them. After that, they walk back to the beach and see the plane in the middle of an ice floe.

a	b	c	d	e	f	g	h	i	j	k	l	m
n	o	p	q	r	s	t	u	v	w	x ✓	y	z

**3 Choose the best end for each sentence.**

1 Phoebe didn't think that they should get closer to the seals because ...

- a  it might be dangerous.
- b  the seals might not like it.
- c  she didn't want to get wet.

2 When the men saw what the children were doing,

- a  they jumped into the water.
- b  they tried to get on the ice floe.
- c  they jumped on their ski-doo.

3 The helicopter was out because the pilot was looking for ...

- a  the two men.
- b  seals.
- c  the children.

4 When the children got to the police station,

- a  the police were still looking for the men.
- b  a police officer took a photo of them.
- c  they were shown some photos to identify the baddies.



1 Use the picture of the men on Student's Book page 98 to complete the dialogue.

Police officer Can you tell us what the two men looked like?  
 Phoebe Yes, one of them had <sup>(1)</sup> dark curly <sup>(2)</sup> \_\_\_\_\_ and a <sup>(3)</sup> \_\_\_\_\_.  
 Alex And he was wearing a <sup>(4)</sup> \_\_\_\_\_ jacket.  
 Police officer And the other one?  
 Patrick He had <sup>(5)</sup> \_\_\_\_\_ hair and <sup>(6)</sup> \_\_\_\_\_ ... I think?  
 Phoebe Yes, he did. I remember them. He had a <sup>(7)</sup> \_\_\_\_\_ on his face and he was wearing a <sup>(8)</sup> \_\_\_\_\_ jacket.  
 Police officer Can you look at these photos and identify the men?  
 Alex Let me see ... yes, this man here.  
 Patrick And this one here.  
 Phoebe That's them. Just how we described them.

2 Read the article and write *t* (true) or *f* (false).

Every year, hundreds of thousands of birds are killed as they make the long journey from Africa to Europe. Birds like turtle doves, nightingales, cuckoos and ospreys spend the European winter on the African continent and they return to Europe in the spring to make nests and lay eggs. In September, they leave again to fly back to where it is warm. Unfortunately, as these birds fly over the south of Europe and the sea north of Africa, many are shot and killed, even though these birds are protected by international laws. Some are eaten, but most are just shot for fun. This means that these traditional summer birds are becoming much more difficult to find in Europe and experts say that some are in real danger. We must stop this killing now!

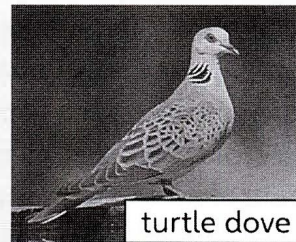

turtle dove



nightingale

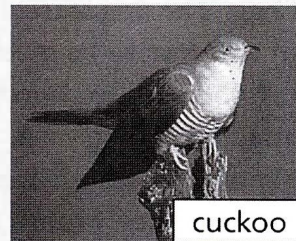

cuckoo

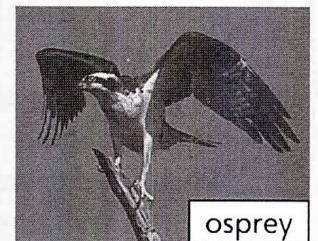

osprey

- 1 The only birds that are shot are turtle doves, nightingales, cuckoos and ospreys.
- 2 The birds spend their lives on three different continents.
- 3 They fly south in September.
- 4 It is illegal to shoot these birds.
- 5 Most of the birds are shot for food.
- 6 It was easier to see birds like cuckoos in Europe in the past.

f

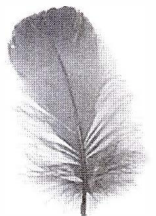

3 Values What can we learn from the story? Colour the words.

We They Hunters doesn't must are care  
 protect look wild big things animals .

1 Read the story about a hiker and his dog. Write t (true), f (false) or ds (doesn't say).

## THE HIKER AND HIS DOG



One summer day, a man went out hiking with his dog. After hiking for many hours in the sun, the man was very thirsty. He looked for a stream to drink from, but he couldn't find one. Then he spotted a rock with water trickling down it. The man sat down and took a cup from his bag. The dog started barking, but the man told him to be quiet. He put the cup against the rock to collect the water and he waited for a long time. When the cup was almost full, he put it to his mouth. At that moment, the dog pushed the cup out of the man's hand.

The man was very angry. Again he put the cup against the rock and waited. As soon as he went to drink from the cup, the dog pushed it out of his hand again.

Now the man was really angry. For the third time, he put his cup against the rock. This time he was very careful and held the cup very tightly. When he put the cup to his mouth, the dog jumped on him from behind and the cup fell on the ground. The man was so angry now that he grabbed a stone and threw it at the dog.

He decided to climb up the rock to find where the water was coming from. It was difficult, but when he finally found the pool, he knew why the dog was behaving so strangely. There was a dead sheep in the pool. The water was poisonous and the dog could smell it. The man quickly climbed down and apologised to his dog. He was very thirsty, but also happy. The only reason why he was still alive was because dogs have better noses than humans.

- 1 The man was thirsty because it was a hot day.
- 2 The man had another dog at home.
- 3 The dog barked because he could see something on top of the rock.
- 4 It took a long time to fill the man's cup.
- 5 The dog pushed the cup from the man's hand four times.
- 6 The man threw a stone at the dog because he was very angry.
- 7 It wasn't dangerous to drink the water from the pool.
- 8 The man was sorry about throwing the stone.

t



1 CD4  
19

Listen to Emma talking to James about buying a present for her brother.  
Tick (✓) A, B or C.

- 1 Emma's brother likes to read  
A science fiction.  B detective stories.  C fairy tales.
- 2 The book which James has just read is  
A *The Polar Bear*.  B *The Kites*.  C *The Polar Kids*.
- 3 The book is about two children who have  
A no friends.  B run away.  C no aunt.
- 4 Emma's brother will be  
A eleven.  B twelve.  C nine.
- 5 The bookshop is in  
A Bridge Road.  B Park Lane.  C River Road.
- 6 The price of the book was  
A £12.  B £10.  C £22.

2 Work in pairs. Student A: Here is some information about a winter sports shop.  
Student B: You don't know anything about the shop. Ask and answer questions.

## Student A

Email: snowsfun@winipegsports.ca

Tel: 869421

Sunday 1.00 p.m.–7.00 p.m.  
Tuesday–Saturday 10.00 a.m.–9.00 p.m.

Best prices in town!

Get everything you need for your holidays!

Largest selection of skis, sledges and  
snowboards in Winnipeg

34 Rich Street

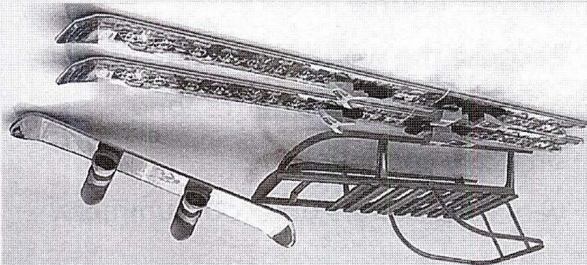

The Winter Sports Shop

## Student B

مرجع زبان ایرانیان

## The Winter Sports Shop

- address?
- big or small shop?
- opening times?
- good prices?
- telephone number?
- email?

**1** Look at the pictures and write the words.

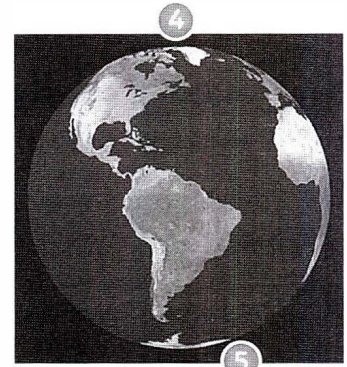
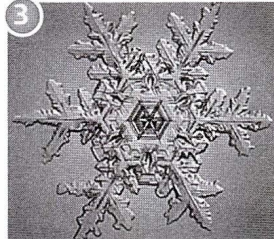
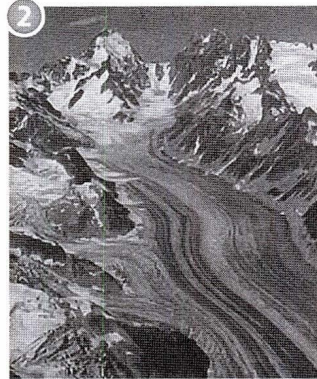

1 a continental glacier

2 a \_\_\_\_\_ glacier

3 a \_\_\_\_\_

4 the \_\_\_\_\_  
5 the \_\_\_\_\_

**2** Read the text on Student's Book page 102 again. Complete the sentences.

- 1 Glaciers are rivers of ice which can be very deep.
- 2 Glaciers which you find in \_\_\_\_\_ are called valley glaciers.
- 3 The glaciers at the North and the South poles are called \_\_\_\_\_ or ice \_\_\_\_\_.
- 4 About \_\_\_\_\_ of the surface of the world is covered by ice.
- 5 When the ice of a glacier becomes thick and heavy, the glacier starts to \_\_\_\_\_.
- 6 Continental glaciers become bigger and bigger until they reach the sea. Then big blocks of ice break off the edges. These blocks of ice are called \_\_\_\_\_.

**3** Match the sentence halves.

- |                                      |                                       |                                      |
|--------------------------------------|---------------------------------------|--------------------------------------|
| 1 You can find glaciers              | a <input type="checkbox"/>            | but only very slowly.                |
| 2 Glaciers are constantly moving,    | b <input type="checkbox"/>            | heavier, it turns into ice.          |
| 3 The longest glaciers are           | c <input type="checkbox"/>            | because the world is getting warmer. |
| 4 Glaciers only exist in places with | d <input type="checkbox"/>            | more than 150 kilometres long.       |
| 5 When the snow becomes thicker and  | e <input checked="" type="checkbox"/> | on every continent.                  |
| 6 These days many glaciers melt fast | f <input type="checkbox"/>            | very cold winters and cool summers.  |



**1 Read the webpage. Write questions for the answers.**

irLanguage.com

The region of Patagonia is at the cold southern tip of the continent of South America. Most of the glaciers in South America are melting very quickly as a result of global climate change and many people are worried about this. However, there is one glacier in the south of Argentina that is not melting at all. It's called Perito Moreno. Scientific experts have said that the ice mass of the glacier has become bigger. This is because of the cold Patagonian wind which stops the glacier from melting in the summer.



1 *Where is Patagonia?*

It's at the southern tip of South America.

2

Because the world climate is changing.

3

Perito Moreno is in the south of Argentina.

4

They have said that it has become bigger.

5

The cold wind in Patagonia.

**2 Read Pedro's text. Underline the information in different colours.**

- Where does Pedro live? (red)
- What are the two names of the mountain? (blue)
- How high is the mountain? (green)
- Why is it very interesting? (orange)

**3 Research and write about another mountain.**

I live in Mexico City. Mexico has got a lot of mountains. One of them is called Orizaba. This is an Aztec name and it means 'Star mountain'. Orizaba is more than 5,600 m high and it is 190 km east of my city. It is a very interesting mountain because it has got a glacier on top, but it is also a dormant volcano! One day, I hope I can climb Orizaba.

Pedro Gutiérrez

**1 Choose six words or phrases to complete the sentences.**

- |              |   |   |                            |              |
|--------------|---|---|----------------------------|--------------|
| haven't      | 1 | When the weather gets warmer, lots of ice <i>may melt</i> | in the Arctic.             | are          |
| may melt     | 2 | Some animals _____  | very rare                  | may not come |
| aren't       | 3 | Seals are very good swimmers,                             | _____                      | they?        |
| is           | 4 | It _____  | rain tomorrow, so we could | might live   |
| might not    | 5 | Those maps _____  | very useful,               | might become |
| aren't they? | 6 | The weather is great today,                               | _____                      | isn't        |
| it?          |   |   |                            |              |

**2 There is a word missing from these sentences. Write each sentence with a word from the box in the correct place.**

find   might   isn't   get   aren't   is

- 1 My new skateboard is cool, it?  
My new skateboard is cool, isn't it?
- 2 He have to wait a long time, so he's taken a book.  
\_\_\_\_\_
- 3 Your friends are hungry, they?  
\_\_\_\_\_
- 4 We may your key in the garden, so let's look there.  
\_\_\_\_\_
- 5 Tomorrow Saturday, isn't it?  
\_\_\_\_\_
- 6 When the climate changes, the summers might longer.  
\_\_\_\_\_

**3 Complete the sentences with your own ideas.**

- 1 Your friends are \_\_\_\_\_, \_\_\_\_\_ ?
- 2 This weekend I may \_\_\_\_\_ .
- 3 \_\_\_\_\_, isn't he?
- 4 We may \_\_\_\_\_ next summer.
- 5 \_\_\_\_\_, are you?
- 6 I'm not sure how I will get to your party, but I might \_\_\_\_\_ .







# The Jurassic Age

## 1 Complete the crossword.

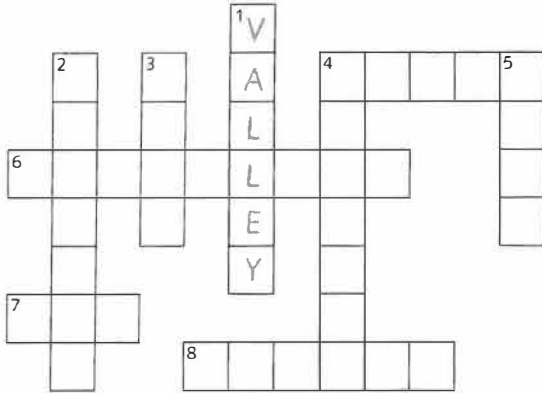

### Across

- 4 very wet muddy land
- 6 a place with lots of grass
- 7 a cylinder of wood from a tree
- 8 a small river

### Down

- 1 the land between two mountains
- 2 where the land meets the sky
- 3 a type of plant with lots of leaves
- 4 the time in the morning when we first see light
- 5 a very small lake or pool

## 2 Think! Write the words from Activity 1. Add other words that you know.

- 1 Words connected with water: pond \_\_\_\_\_, \_\_\_\_\_, \_\_\_\_\_  
Can you add any more? \_\_\_\_\_
- 2 Words connected with plants and trees: \_\_\_\_\_, \_\_\_\_\_, \_\_\_\_\_  
Can you add any more? \_\_\_\_\_
- 3 Words connected with the sky: \_\_\_\_\_, \_\_\_\_\_  
Can you add any more? \_\_\_\_\_

## 3 Complete the dialogue with the words from the box.

past dinosaur swamp joking future pond ~~strange~~ horizon

Alex Wow, this place is <sup>(1)</sup> *strange* \_\_\_\_\_. Any idea where we are?

Patrick Look at that muddy <sup>(2)</sup> \_\_\_\_\_. I've never seen anywhere like it. I think we're in the <sup>(3)</sup> \_\_\_\_\_.

Phoebe No, I think we're in the <sup>(4)</sup> \_\_\_\_\_. I think we're in a time before people walked on Earth.

Patrick Why do you think that?

Phoebe Well, if you look over there on the <sup>(5)</sup> \_\_\_\_\_, I think there's a <sup>(6)</sup> \_\_\_\_\_.

Alex A dinosaur? You're <sup>(7)</sup> \_\_\_\_\_.

Patrick She isn't. Look over there by the <sup>(8)</sup> \_\_\_\_\_. There are some dinosaurs feeding.



**1 Match the sentences from the box with the pictures.**

If I went to my best friend's house, I'd show him my bike.  
 If I saw girls from our class, I'd wave.  
~~If I had a lot of money, I'd buy an amazing mountain bike.~~  
 If I had an amazing new mountain bike, I'd ride around all day.



- 1 If I had a lot of money, I'd buy an amazing mountain bike.      3 \_\_\_\_\_
- 2 \_\_\_\_\_      4 \_\_\_\_\_

**2 Complete the sentences with the correct form of the verbs in brackets.**

- 1 If I had a lot of money, I'd spend my holiday in the jungle. (have)  
 2 If I \_\_\_\_\_ into the jungle, I'd take a camera with me. (go)  
 3 If I \_\_\_\_\_ a hot air balloon, I'd fly above the trees. (have)  
 4 If I \_\_\_\_\_ a jaguar, I'd take a photo. (see)  
 5 If I \_\_\_\_\_ tired, I'd sleep in a hammock. (be)

**3 Look at the pictures and write sentences with *If I*.**

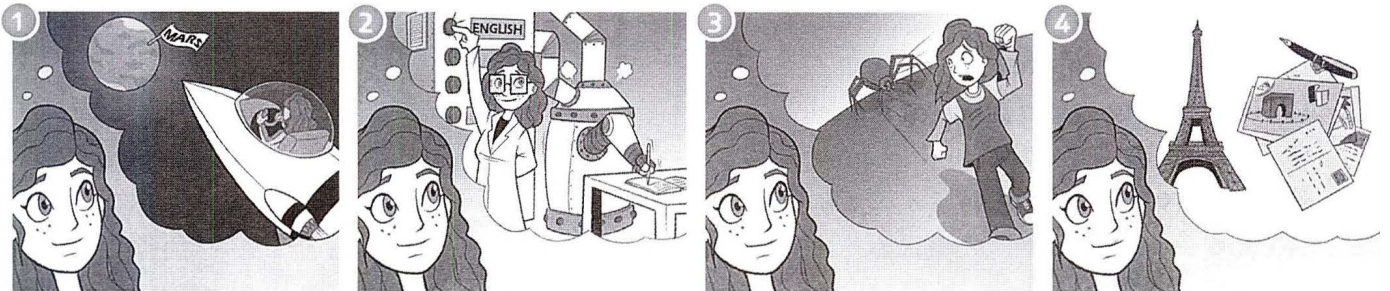

1 If I had a rocket, I'd fly to Mars.



**1 Match the song phrases with the definitions. Match them with the pictures.**

- 1 to hang out
- 2 to mess about
- 3 to poke
- 4 to creep up on

- a  to point your finger (or horn!) in someone
- b  to walk up quietly behind
- c  to spend time (not doing anything special)
- d  to have fun doing silly things

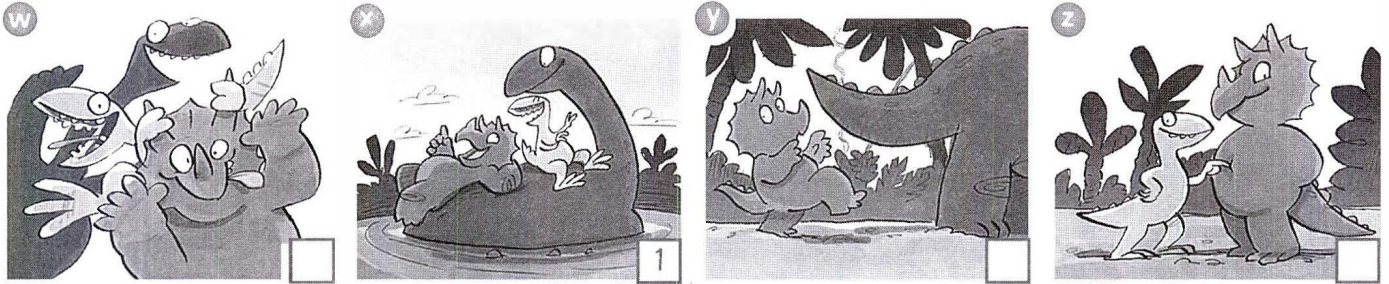

**2 Listen and say the words.**

short awful  
ball dinosaur

**Phonics tip**

There are different ways of spelling the *or* sound.



**3 Complete the sentences with the words from the box. Match them with the pictures.**

dinosaurs small walking  
autumn tall stories

- 1 Are you short or *tall* ?
- 2 Do you prefer lions or \_\_\_\_\_ ?
- 3 Do you prefer summer or \_\_\_\_\_ ?
- 4 Would you like a big piece of cake or a \_\_\_\_\_ one?
- 5 Do you prefer running or \_\_\_\_\_ ?
- 6 Do you usually read \_\_\_\_\_ that are fact or fiction?

- b
- 
- 
- 
- 
- 



**4 Listen and check. Ask and answer with a partner.**



**1 Match the questions with the answers.**

If you had a lot of money, ...

- |   |                                      |   |                          |                                |
|---|--------------------------------------|---|--------------------------|--------------------------------|
| 1 | where would you buy a house?         | a | <input type="checkbox"/> | To the moon.                   |
| 2 | what pet would you buy?              | b | <input type="checkbox"/> | All my friends.                |
| 3 | what would you do for your birthday? | c | <input type="checkbox"/> | In a bank.                     |
| 4 | who would you give some of it to?    | d | <input type="checkbox"/> | Take my friends to Disneyland. |
| 5 | where would you keep it?             | e | <input type="checkbox"/> | A tropical snake.              |
| 6 | where would you go on holiday?       | f | <input type="checkbox"/> | 1 In London, near the Thames.  |

**2 What would Paul do if ... ? Write questions and match the answers with the questions.**



- 1 What would Paul do if he saw a thief in a shop?



- 2 \_\_\_\_\_  
to New York?

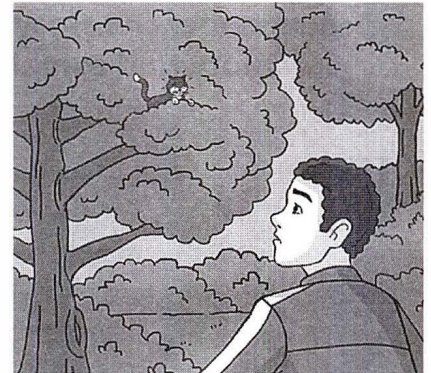

- 3 \_\_\_\_\_  
a cat in a tree?

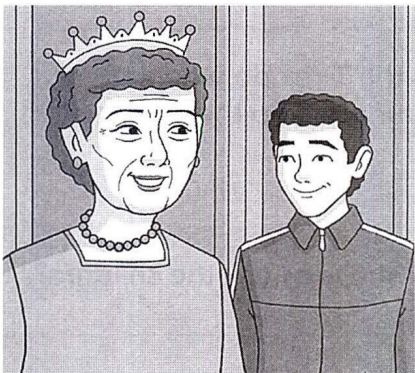

- 4 \_\_\_\_\_  
the British Queen?

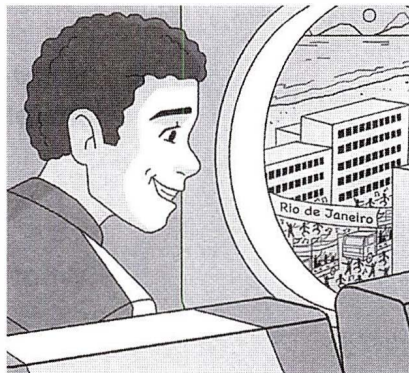

- 5 \_\_\_\_\_  
to Rio de Janeiro?

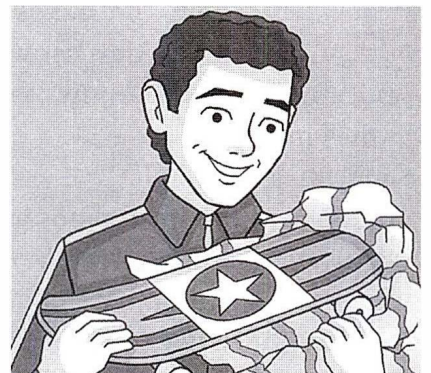

- 6 \_\_\_\_\_  
a new skateboard?

- |   |                          |                          |   |                          |                                  |
|---|--------------------------|--------------------------|---|--------------------------|----------------------------------|
| a | <input type="checkbox"/> | He'd go to Central Park. | d | <input type="checkbox"/> | He'd climb the tree and save it. |
| b | <input type="checkbox"/> | He'd go to the carnival. | e | <input type="checkbox"/> | He'd practise a lot.             |
| c | <input type="checkbox"/> | 1 He'd call the police.  | f | <input type="checkbox"/> | He'd say 'Hello'.                |

1 Match the dinosaur names from the box with the pictures.

T-rex velociraptor pterosaur triceratops

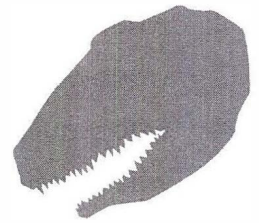
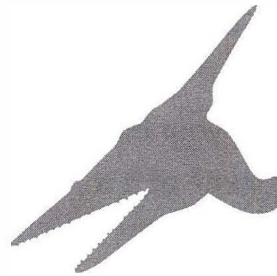
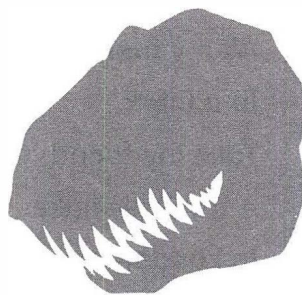
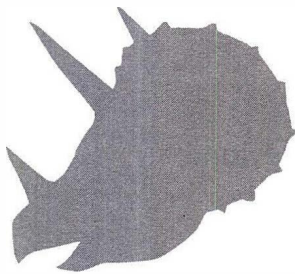

1 triceratops

2

3

4

2 Remember the story. Read the summary and complete the words.

The children see a triceratops eating <sup>(1)</sup> bushes \_\_\_\_\_. Alex walks towards it. Phoebe says that he might <sup>(2)</sup> s \_\_\_\_\_ it. The dinosaur quickly walks away, but it's not Alex who is scaring it. It's a <sup>(3)</sup> g \_\_\_\_\_ of small dinosaurs which are coming out of the jungle. Patrick says that they don't need to <sup>(4)</sup> w \_\_\_\_\_ because the dinosaurs are only small. Then one of them opens its <sup>(5)</sup> m \_\_\_\_\_ and shows lots of sharp <sup>(6)</sup> t \_\_\_\_\_. Alex knows that they are velociraptors and he knows that he is in trouble as they make a <sup>(7)</sup> c \_\_\_\_\_ around him. Suddenly a huge <sup>(8)</sup> h \_\_\_\_\_ appears and grabs one of the small dinosaurs, so the others run away. The children are now safe from the velociraptors, but in big <sup>(9)</sup> d \_\_\_\_\_ from a T-rex! They start to run and just as the huge <sup>(10)</sup> d \_\_\_\_\_ is going to catch them, they are picked up by a pterosaur in its <sup>(11)</sup> b \_\_\_\_\_. The flying dinosaur takes the children back to its <sup>(12)</sup> n \_\_\_\_\_ and drops them towards its <sup>(13)</sup> h \_\_\_\_\_. Luckily, the gate appears and takes the Time Travellers back to the safety of their <sup>(14)</sup> c \_\_\_\_\_.

3 Answer the questions.

- Why does Patrick think that Alex is mad?  
Because he walks towards the \_\_\_\_\_ triceratops.
- Why isn't Alex scared of the triceratops?  
\_\_\_\_\_
- What are the velociraptors doing when the T-rex appears?  
\_\_\_\_\_
- What does the T-rex do when the pterosaur picks up the children?  
\_\_\_\_\_
- What does Mr Davis ask the children?  
\_\_\_\_\_
- What does Patrick find in his pocket?  
\_\_\_\_\_



1 How much do you remember about the Time Travellers' adventures? Do the quiz.

## The Great Big Time Travellers' Quiz

- 1 What knocks over the jar and causes the explosion which starts the children on their adventures again?
 

a Patrick's cap <input type="checkbox"/>	b Patrick's goggles <input type="checkbox"/>	c Patrick's pen <input type="checkbox"/>
--	--	--
- 2 What treasure do the children dig up on the island?
 

a Diamonds <input type="checkbox"/>	b Bracelets <input type="checkbox"/>	c Gold coins <input type="checkbox"/>
-------------------------------------	--------------------------------------	---------------------------------------
- 3 What colour buttons open the parachute on the jet pack?
 

a Yellow and blue <input type="checkbox"/>	b Red and orange <input type="checkbox"/>	c Purple and green <input type="checkbox"/>
--	---	---
- 4 What creature lands on Phoebe's head inside the pyramid?
 

a A scorpion <input type="checkbox"/>	b A spider <input type="checkbox"/>	c A snake <input type="checkbox"/>
---------------------------------------	-------------------------------------	------------------------------------
- 5 What sport are the children watching when Patrick hurts his foot?
 

a Boxing <input type="checkbox"/>	b Fencing <input type="checkbox"/>	c Wrestling <input type="checkbox"/>
-----------------------------------	------------------------------------	--------------------------------------
- 6 What do the children help Mr Fisher put on his cart when they are escaping from the Great Fire of London?
 

a A table <input type="checkbox"/>	b A chest <input type="checkbox"/>	c Some chairs <input type="checkbox"/>
------------------------------------	------------------------------------	--
- 7 What does Professor Potts' Homework Express give as the answer to  $2,345 \times 4,567$ ?
 

a New York <input type="checkbox"/>	b London <input type="checkbox"/>	c Paris <input type="checkbox"/>
-------------------------------------	-----------------------------------	----------------------------------
- 8 What are the NASA engineers all drinking when they fall asleep?
 

a Tea <input type="checkbox"/>	b Coffee <input type="checkbox"/>	c Hot chocolate <input type="checkbox"/>
--------------------------------	-----------------------------------	--
- 9 What rescues the children in the North Pole?
 

a A boat <input type="checkbox"/>	b A ski-doo <input type="checkbox"/>	c A helicopter <input type="checkbox"/>
-----------------------------------	--------------------------------------	---
- 10 What scares the triceratops?
 

a A T-rex <input type="checkbox"/>	b Some velociraptors <input type="checkbox"/>	c A pterosaur <input type="checkbox"/>
------------------------------------	---	--

Check back through the stories in the Student's Book. Give yourself a point for each answer that you remembered correctly.

### ARE YOU READY TO BE A TIME TRAVELLER?

**0-3 points** Oh dear! You didn't remember very much. You've forgotten almost as much as Phoebe, Alex and Patrick! You need to read the stories again before you can go time travelling.

**4-7 points** Not bad, but you still need a bit more practice. Read the stories again and you should be ready for time-travelling adventures.

**8-10 points** Brilliant! You're ready for time travelling now. Be careful in your next Science lesson!



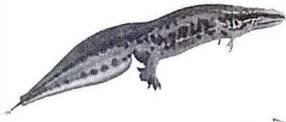

**1 Complete the cards with the animal names and the star facts from the box.**

Blue feathers Powerful tail Four wings Spiky back  
Green head Swim backstroke Homes in holes Long legs

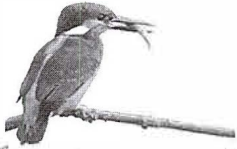
**1 POND LIFE STARS**  
Newt  
  
Powerful tail

**2 POND LIFE STARS**  



**3 POND LIFE STARS**  

**4 POND LIFE STARS**  

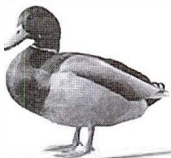
**5 POND LIFE STARS**  

**6 POND LIFE STARS**  

**7 POND LIFE STARS**  

**8 POND LIFE STARS**  

**2 Read the texts on Student's Book page 112 again. Which animal is it?**

- 1 This creature gets its name from a body part. stickleback
- 2 This bird stands like a statue.
- 3 This animal uses its tail to move through the water.
- 4 This insect comes in many different colours.
- 5 It's not difficult to find this bird.
- 6 This creature has two different names. /
- 7 People often think that this mammal is a different animal.
- 8 This bird is difficult to see.

**3 Values What can we learn about the world? Colour the words.**

The world Don't around behind us take  
anything are is horrible sad wonderful .



**1** Read the sentences about Holly's trip with the nature club. Choose the best word (A, B or C) for each space.

- 1 Holly ... the other members of the club in the school car park at 9 o'clock.  
A saw                      **B** met                      C found
- 2 The weather wasn't good, ... she took a waterproof coat.  
A so                      B but                      C because
- 3 Unfortunately, she ... her binoculars at home.  
A left                      B had                      C took
- 4 They saw lots of mallards, but they ... see any kingfishers.  
A not                      B wasn't                      C didn't
- 5 The packed ... had cheese sandwiches, but Holly doesn't like these, so she didn't eat anything.  
A breakfast                      B lunch                      C dinner
- 6 It was a pretty bad day and she was very ... to get back home.  
A sad                      B angry                      C happy

**2** Holly's dad asked her about the trip. Put the dialogue in order.

- Dad Oh dear. What went wrong?
- 1 Dad So how was the trip, Holly?
- Dad Ah ... yes, I saw them on your bed this afternoon. What else happened?
- Dad So you're hungry. OK, I'll cook you your favourite dinner.
- Dad Why not?
- Holly Well, I didn't eat anything because they only had cheese sandwiches.
- Holly Pizza! Dad, you're the best!
- Holly Because I left my binoculars at home.
- Holly Everything. For a start, I couldn't see any birds very well.
- Holly Oh Dad, it was terrible!

**3** Write about an animal that you can find in ponds where you live. Find a photo or draw a picture of it.

A I A

**My pond life star**

My pond life star is called a painted frog. It's got dark spots on its back and its stomach is white or yellow. It's got big, round eyes and a pointed nose. Its skin is smooth, but you can feel two lines which run down its back from behind its eyes.



**1** Read the article and write *t* (true), *f* (false) or *ds* (doesn't say).



In 2007 a Russian hunter was walking in Siberia when he saw something poking out of the ground. He thought it was a deer, but when he looked closer, he saw that it was something much more exciting. Paleontologists arrived to dig the object from the ice and they found the frozen body of a six-month-old woolly mammoth that died more than 40,000 years ago. It didn't have any hair, but the rest of it was perfect. The scientists have now given the mammoth a name, Lyuba, and they hope that they can learn a lot about the animal by studying the fossil.

- 1 The hunter who found the fossil was from South America.  *f*
- 2 He dug the fossil out of the ice.
- 3 The mammoth was under a year old when it died.
- 4 The mammoth fossil had small tusks like an elephant.
- 5 They found fossilised hair on the body.
- 6 Scientists are going to study it.

**2** Read the text on Student's Book page 114 again. Put the sentences in order.

- The dinosaur fossil goes on display for people to see.
- Insects eat the dinosaur.
- The dinosaur bones become a type of rock.
- The dinosaur bones lie at the bottom of the water.
- Scientists find the fossilised bones.
- 1 The dinosaur falls into a swamp.
- The dinosaur bones are pushed against the rocks.
- The swamp becomes rock.

**3** **Think!** Look at the dinosaur exhibits and complete the signs. Use the story on Student's Book pages 110–111 to help you.

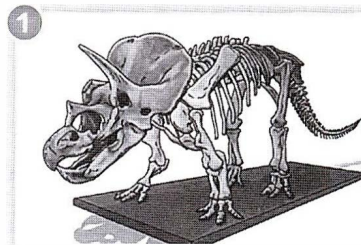

This is a triceratops skeleton.  
One of its horns is missing.

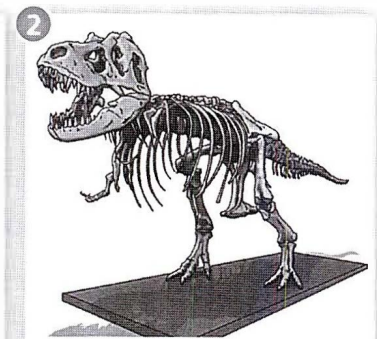

This is a \_\_\_\_\_ skeleton.  
One of its \_\_\_\_\_ is missing.

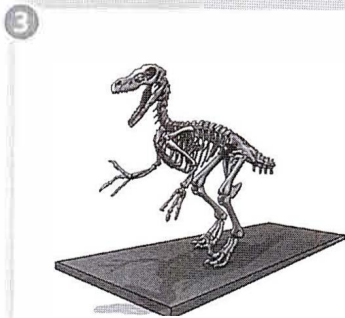

This is a \_\_\_\_\_ skeleton.  
Most of its \_\_\_\_\_ is missing.

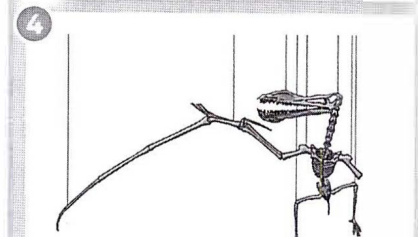

This is a \_\_\_\_\_ skeleton.  
One of its \_\_\_\_\_ is missing.



1 **Think!** Read Ryan's email. What mistake has he made? How do you know?

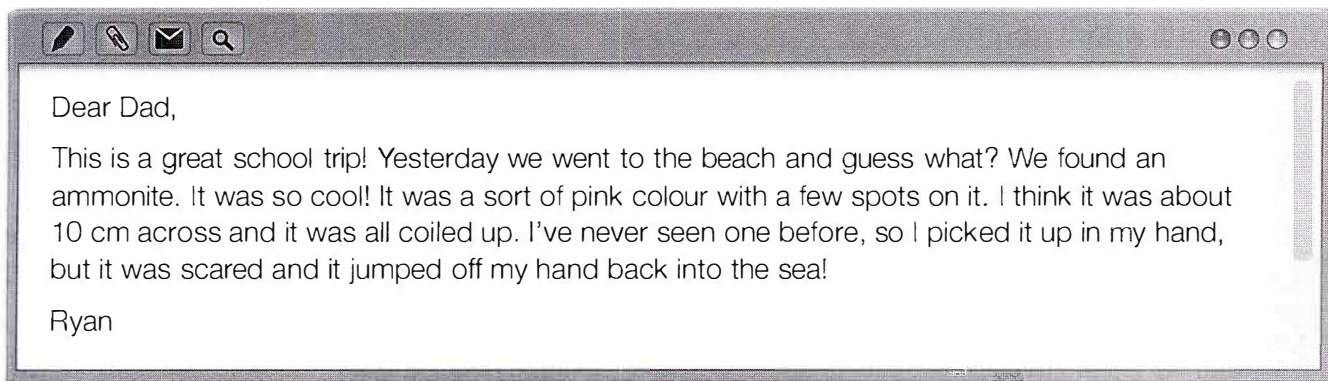

2 Read the text on Student's Book page 115 again and complete the card.

Dinosaur dig	Ammonites	
When did they live?		240–65 million years ago
How big were they?		_____
What did they look like?		_____
What did they eat?		_____
What were they eaten by?		_____
What modern animals are in the same family?		_____



3 Find words in the ammonite to complete the sentences.



- 1 The distance across a circle is called its diameter.
- 2 A \_\_\_\_\_ is a large ancient sea lizard.
- 3 Ammonite shells are \_\_\_\_\_, like a spiral.
- 4 Your \_\_\_\_\_ bones are in your mouth.
- 5 A \_\_\_\_\_ is a relative of the ammonite.
- 6 Squid and ammonites have long body parts called \_\_\_\_\_.
- 7 Your \_\_\_\_\_ is the bone which runs down your back.
- 8 If something is \_\_\_\_\_, it isn't fixed to anything.

- 1 Make three sentences with the phrases in the diamond. Use three different phrases in each sentence.

What would you do \_\_\_\_\_  
 \_\_\_\_\_  
 \_\_\_\_\_  
 \_\_\_\_\_



- 2 Draw lines and complete the sentences with the words from the box.

if you had   do if   I'd go   ~~buy an~~   if I   I were

1 If I had a	a time machine,	_____	in a film about dinosaurs.
2 If I had	you _____		to the year 2166.
3 _____ had a telescope,	lot of money, I'd _____		stars every night.
4 Where would	an actor, I'd like to be _____		a plane?
5 If _____	you fly _____		you saw a dinosaur?
6 What would	I'd look at the _____	buy an _____	amazing new computer.

- 3 Complete the sentences with your own ideas.

- Where would you \_\_\_\_\_ ?
- If I were \_\_\_\_\_ , \_\_\_\_\_ .
- What \_\_\_\_\_ had \_\_\_\_\_ ?
- If I had a super power, \_\_\_\_\_ .
- What would \_\_\_\_\_ met \_\_\_\_\_ ?
- If I were \_\_\_\_\_ , \_\_\_\_\_ every day.





# 1 A blog entry



## Tips for writers

- When you write on the Internet, don't give any information that shows people **exactly** who you are and **exactly** where you live, go to school or spend your free time. People can use this information to hurt you.
- Use a second verb without the 'little words' (*I, he, she, 've, 's, 'm, 's, going to, can*) to give more information in fewer words:  
*I've joined a team **and played** a match.*  
*I can speak **and write** English.*  
*She's going to come **and play** too.*

1 Tick (✓) three safe things to write on the Internet. Cross (X) the three things that you shouldn't write.

- 1 My friends call me Footiefan.
- 2 Mum's the head teacher at Ely School.
- 3 I go to Art Club on Mondays.
- 4 The party's at my house: 4 Mill Lane, York!
- 5 My best friend is in class 7B.
- 6 I go to Cross Street Tennis Club on Fridays at 4.15.

2 Complete the sentences with the verbs from the box.

did given joined listening play

- 1 I've started swimming and joined a club.
- 2 Dan went home and \_\_\_\_\_ his homework.
- 3 I'm reading and \_\_\_\_\_ to music.
- 4 She's going to sing and \_\_\_\_\_ the violin.
- 5 He's finished his project and \_\_\_\_\_ it to Mrs Tate.



3 Imagine you are a new student in Phoebe, Alex and Patrick's class. Write a blog entry. Include the points below, but you can invent information and use your own ideas. Remember to join verbs in one sentence without the little words.

- Safe information about yourself
- Two things that you have done since you started at the new school
- How the explosion happened in your last Science class

## Check your writing

- Is all your information safe? \_\_\_\_\_
- Did you join verbs without little words to make longer sentences? \_\_\_\_\_







# Addresses



## Tips for writers

- When you send emails or letters, write the address correctly. This information is as important as the information in your email or letter.
- When you give an email address in English, say *dot* for '.' and *at* for '@'.  
meg.edmonds@webmate.co.uk  
= 'meg dot edmonds at webmate dot co dot UK'

**1** Address the two envelopes with the information from the box.

JAMAICA MUM MY1 1 Pyramid Street  
Giza ~~Captain Eye patch~~ 3 Parrot Avenue  
EGYPT MY SH1P Pharaoh Tutankhamun  
Treasure Town

Name -----> (1) Captain Eye-patch   
 Number and Road -----> (2) \_\_\_\_\_  
 Town/City -----> (3) \_\_\_\_\_  
 Postcode -----> (4) \_\_\_\_\_  
 Country -----> (5) \_\_\_\_\_

Name -----> (6) \_\_\_\_\_   
 Number and Road -----> (7) \_\_\_\_\_  
 Town/City -----> (8) \_\_\_\_\_  
 Postcode -----> (9) \_\_\_\_\_  
 Country -----> (10) \_\_\_\_\_

**2** Imagine that an English friend is coming on holiday to your town/city. Send a guidebook and invite the family to your house. Give information about how to get there (take a bus/train/taxi).

I'm sending you a guidebook which has all the streets in it. Please tell your parents that the easiest way is to \_\_\_\_\_  
 \_\_\_\_\_  
 \_\_\_\_\_

**3** Address the envelope to your English friend. Use the ideas in the box or your own ideas. The postcode starts with two letters from the name of the town.

WH15 9GA RE15 0AX  
Green Lane Bridge Avenue  
Redville Whitely

(1) \_\_\_\_\_   
 (2) \_\_\_\_\_  
 (3) \_\_\_\_\_  
 (4) \_\_\_\_\_  
 (5) \_\_\_\_\_

## Check your writing



- Is the envelope correctly addressed? \_\_\_\_\_





# An email to complain



## Tips for writers

- When you write to complain, use polite phrases such as *Please could you*.
- Explain the problem clearly.

**1** Read Clare's email. Why didn't the shop reply? Complete the reasons with the words from the box.

polite hasn't when

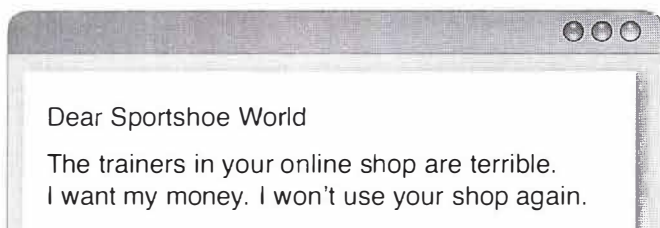

- 1 She \_\_\_\_\_ explained the problem.
- 2 She hasn't said \_\_\_\_\_ she bought the trainers.
- 3 Her email isn't \_\_\_\_\_.

**2** Clare's sister wrote a better email. Find phrases that mean the same as the phrases below.

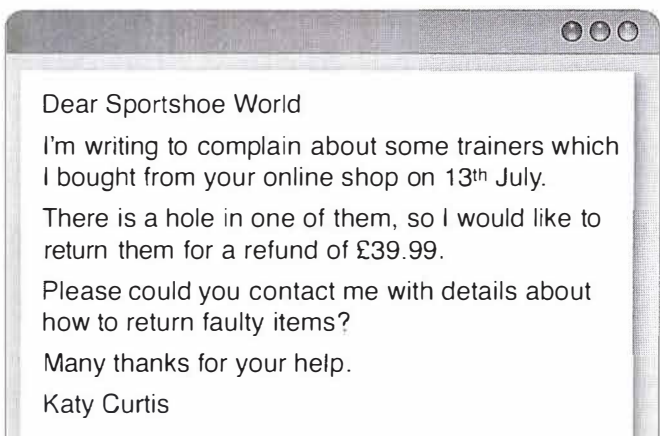

- 1 send them back to the shop: \_\_\_\_\_
- 2 when a shop gives you money: \_\_\_\_\_
- 3 things that aren't right: \_\_\_\_\_

**3** You can ask for other things too. Match the requests with what the shop sends.

I would like to return them in exchange

- 1 for a replacement pair
  - 2 for a voucher off a new order
  - 3 for a pair of Go! trainers, number 4507, black, size 3
- a  a different pair of trainers
- b  a pair of the same trainers
- c  a kind of 'money' which you can use in their online shop

**4** Write an email to complain.

You bought the game 'Basketball Mad' from Toys4You last week. One of the hoops is broken. Ask for a refund, a new hoop or a different sports game.

## Check your writing

- Swap emails with a partner. Does your partner think yours is polite? \_\_\_\_\_



# A postcard



## Tips for writers

- When you write postcards, use informal language to show your feelings:  
Use exclamations, not always whole sentences with verbs: *Amazing!*  
Add comments in brackets or use dashes:  
*The hotel is great (fab food) and ...*  
*There's a theme park too – brilliant!*
- Put the day or date and then use words like *today / tomorrow / yesterday.*



**3** Write two postcards: one from a school trip to someone in your family and one from a family holiday to a school friend. Use informal language, comments and time phrases.

---

---

---

---

---

---

---

---

---

---

---

---

---

---

---

---

---

---

---

---

**1** Read the postcards. Are the expressions positive 😊 or negative ☹️?

Tues 21<sup>st</sup>  
Hi Joe  
I'm writing this on the beach. The sea's warm, but guess what? I found half a burger in the water. Gross or what! There are two theme parks here – this place rocks! Tomorrow we're going to see the castle (Dad's lame idea ... BORING!), but the day after that, we're going to the water park. Awesome! I love water parks.  
See you at school ... only two weeks now.  
George

- 1 gross ☹️      3 lame
- 2 rocks       4 awesome

**2** Read the postcard again and complete the sentences.

- George is visiting the castle on \_\_\_\_\_.
- He's going to the water park on \_\_\_\_\_.
- They start school in \_\_\_\_\_.

## Check your writing

- Did you use all the expressions from Activity 1? \_\_\_\_\_
- What time phrases did you use?
- How many exclamations and comments did you add?





# A story



## Tips for writers

- When you use direct speech in a story, use different verbs to make your story interesting.
- Verbs like *said* can go **before** or **after** a name or a noun:  
*'Yes, it can,' said Professor Potts.*  
*'Yes, it can,' the professor said.*  
The verb always goes **after** a pronoun:  
*'Yes, it does,' she said.*  
*'Yes, it does,' said she.*
- Use speech marks and commas, but don't add commas after question marks or exclamation marks:  
*'Oh no!' she exclaimed.*

**1** Complete the story with the words from the box. Underline twelve verbs of speech.

button doesn't French quietly  
robot story

'Meet my amazing (1) robot !' the professor exclaimed.

'Can it help me with my homework?' asked Hannah.

'Certainly,' replied the professor. 'Robotolot is the most amazing robot in the world,' he boasted.

'That's great,' explained Hannah, 'because I need to write a (2) \_\_\_\_\_ in French and I'm not very good at it.'

'No problem. Robotolot will help you,' the professor promised and he pressed a (3) \_\_\_\_\_ on his incredible robot.

'GREETINGS, HUMAN GIRL! WHAT IS YOUR NAME?' said the robot.

'Je m'appelle Hannah,' answered Hannah. Then she whispered (4) \_\_\_\_\_ to the professor, 'I'm answering in (5) \_\_\_\_\_.'

'WHAT IS YOUR NAME?' repeated the robot.

'Je m'appelle Hannah!' she laughed.

'WHAT IS YOUR ...' but there was a whirring sound as the professor turned it off again.

'Oh dear,' sighed the professor. 'Robotolot (6) \_\_\_\_\_ speak French.'

**2** Complete these verbs from the story.

1 r e p e a t e d      4 s \_\_\_\_\_

2 b \_\_\_\_\_      5 r \_\_\_\_\_

3 p \_\_\_\_\_      6 l \_\_\_\_\_

**3** Write a story about a machine. Use ideas from Student's Book or Workbook page 73, or your own. Include different verbs of speech.

## Check your writing

- How many different verbs of speech did you use? \_\_\_\_\_
- Did you use commas and speech marks correctly? \_\_\_\_\_

# 7 A post on a forum



## Tips for writers

- When you take part in an online discussion, think about the topic before you write. If you write silly things, people won't want you to take part.
- Use phrases to give your opinions:  
*I'm in favour of / against ...*  
*If you ask me, ...* *In my opinion, ...*

### 1 Read the posts and answer the questions.

Author	Space exploration
Wonder1	Yes, I'm in favour of exploring space. Finding out about other planets, for example Mars, helps us to understand our planet, Earth.
Lizard	In my opinion, it's a waste of money. My dad said that they sent something called Beagle 2 to Mars in 2003, but it never made contact with Earth and now they can't find it! £45 million! We shouldn't spend all that money when people on Earth have serious problems, such as not having enough food.
Digger	Yeah, like me! I'm really hungry ...
Geddit	Digger, go and watch TV if you can't say anything useful. This is a serious topic. If you ask me, projects like trying to find water on Mars are a waste of time. How can it help?
Kencan	Because if they find water, it means that things could live on Mars. I think it's an amazing idea.

- 1 Who agrees with space exploration?  
\_\_\_\_\_
- 2 Who doesn't agree?  
\_\_\_\_\_
- 3 Whose post is a waste of time?  
\_\_\_\_\_

### 2 Use the opinion phrases to write sentences with gerunds.

- 1 (learn / about other planets)  
I'm in favour of learning about other planets .
- 2 (help / people on Earth / more important)  
In \_\_\_\_\_ .
- 3 (send / rockets into space / a waste of money)  
\_\_\_\_\_ you \_\_\_\_\_ .

### 3 Choose a new topic that interests you. Write a post for or against. Use phrases from the forum posts and gerunds.

Navigation icons: back, forward, home, refresh, search

---

---

---

---

---

---

---

---

---

---

### Check your writing

- Which opinion phrases did you use?  
\_\_\_\_\_
- Did you spell your gerunds correctly?  
\_\_\_\_\_







# Limericks



## Tips for writers

- In acrostics, spelling is important, but in other poems, **rhythm** and **rhyme** are important.
- Underline the stressed syllables to check your rhythm: *artist, doctor.*
- Circle the rhymes in different colours:  
*day look play book*
- Always read your poem aloud.

**1** This kind of poem is called a limerick. Say the poem and underline the syllables with stresses. The numbers (in brackets) show you how many.

- 1 There was a young woman called Sue (3) ✓ ✓ ✓  
 2 Who had a nice day at the zoo. (3)  
 3 She saw hippos and bats (2) ✓ ✓  
 4 And lots of big cats (2)  
 5 And she fed all the elephants too! (3)

**2** Think about the rhythm of a limerick.

1 Look at *hippos* in line 3. Tick (✓) two other animals that you could use here.

toucans  giraffes  rhinos

2 Look at *elephants* in line 5. Cross out the two animals that you can't use here.

kangaroos crocodiles anacondas

**3** Look at line 1. Write three phrases with the same rhythm as *a young woman*.

*a good teacher*, \_\_\_\_\_,  
 \_\_\_\_\_,

**4** Limericks have two rhyme patterns. Which lines rhyme? Write the numbers.

Lines 1 \_\_\_\_\_, \_\_\_\_\_ and \_\_\_\_\_ rhyme.

Lines \_\_\_\_\_ and \_\_\_\_\_ rhyme.

**5** Limerick writers invent funny names to make the lines rhyme. Complete the opening lines of these limericks with food and drink words.

- 1 There was a professor called Weeze  
Who ate lots of very old *cheese* ...
- 2 There was a young schoolboy from Hakes  
Who said he could make lovely \_\_\_\_\_
- 3 There was a strange artist called Doffy  
Who painted his pictures with \_\_\_\_\_
- 4 There was an old poet from Drickin  
Who spent all her money on \_\_\_\_\_

**6** Read about Lee. Write a limerick. Use Activity 1 to help you.

Lee was a young schoolboy who went for a swim, where he saw amazing things in the sea, like whales and snails. He got home at 3.15.

---

---

---

---

---

---

---

---

**7** Write a limerick. Follow the rules.

---

---

---

---

---

---

---

---

## Check your writing

Look at your two limericks.

- Underline the stresses in each line.
- Circle the rhymes in different colours.



Verb	Past	Past participle	Verb	Past	Past participle
be	was/were	been	leave	left	left
become	became	become	let	let	let
begin	began	begun	lie	lay	lay
break	broke	broken	lose	lost	lost
bring	brought	brought	make	made	made
build	built	built	mean	meant	meant
buy	bought	bought	meet	met	met
catch	caught	caught	pay	paid	paid
choose	chose	chosen	put	put	put
come	came	come	read	read	read
cost	cost	cost	ride	rode	ridden
creep	crept	crept	ring	rang	rung
cry	cried	cried	run	ran	run
cut	cut	cut	say	said	said
die	died	died	see	saw	seen
dig	dug	dug	sell	sold	sold
do	did	done	send	sent	sent
draw	drew	drawn	set	set	set
drink	drank	drunk	shine	shone	shined
drive	drove	driven	shrink	shrank	shrank
eat	ate	eaten	sing	sang	sung
fall	fell	fallen	sit	sat	sat
feed	fed	fed	sleep	slept	slept
feel	felt	felt	speak	spoke	spoken
fight	fought	fought	spend	spent	spent
find	found	found	spin	span	spun
fly	flew	flown	spread	spread	spread
forget	forgot	forgotten	stand	stood	stood
get	got	got	steal	stole	stolen
get up	got up	got up	stick	stuck	stuck
give	gave	given	sweep	swept	swept
go	went	been*	swim	swam	swum
grow	grew	grown	take	took	taken
hang	hung	hung	teach	taught	taught
have got	had	had	tell	told	told
hear	heard	heard	think	thought	thought
hide	hid	hidden	throw	threw	thrown
hit	hit	hit	understand	understood	understood
hold	held	held	wake up	woke up	woken up
hurt	hurt	hurt	wear	wore	worn
keep	kept	kept	win	won	won
know	knew	known	write	wrote	written
lay	laid	laid			

\*We also use *gone*.

*I've been to Mars.* = I've visited Mars.

*He's gone to Mars.* = He's still on Mars!





# Super Minds

Workbook 6

## Are you ready to become one of the Super Minds?

This exciting seven-level course, from a highly experienced author team, enhances your students' thinking skills, improving their memory along with their English.

-  Develop language creatively with activities like role play and project work
-  Focus on functional language with communicative activities
-  Explore social values through the stories and fascinating cross-curricular sections

This Workbook features a page of activities to accompany each page of the Student's Book along with extra writing practice.

FREE extra resources can be downloaded from [www.cambridge.org/elt/superminds](http://www.cambridge.org/elt/superminds)

### مرجع زبان ایرانیان

Super Minds Level	CEFR Level	Cambridge ESOL exams
Level 6	A2 – B1	Towards Preliminary
Level 5	A2	Flyers / Key
Level 4	A1	Movers
Level 3		
Level 2		Starters
Level 1		
Starter		

### Level 6

Student's Book with DVD-ROM

Workbook

Teacher's Book

Teacher's Resource Book with Audio CD

Class Audio CDs

Classware and

Interactive DVD-ROM

### Other resources you can use:

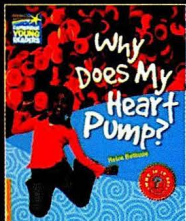

ISBN 978 0521 13742 3

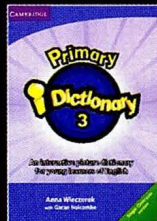

ISBN 978 0521 17587 6

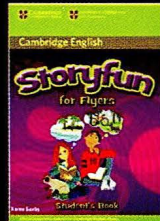

ISBN 978 0521 13410 1



**CAMBRIDGE**  
UNIVERSITY PRESS  
[www.cambridge.org](http://www.cambridge.org)

مرجع آموزش زبان ایرانیان

**IR**  
www.irLanguage.com